

# Architectural Registration Examination

## Building Design & Construction Systems

"Dr. Saum K. Nour, Ph.D."

PE Civil, PE Electrical, PE Mechanical, CPD, CIPE, CFPE,  
LEED AP, AIA

9:00 AM December 21<sup>st</sup> 2013

[snour@Absoluteco.com](mailto:snour@Absoluteco.com)

3839 Birch, Newport Beach, Ca 92660. 949 852 8700. 949  
852 1918 fax

*Covering the Nation*

July 2013 ARE® 4.0 a

**OVERVIEW**

# **Building Design & Construction Systems**

## **DIVISION STATEMENT**

Apply knowledge and skills of building design and construction, including

- environmental,
- social, and
- economic issues,
- project and practice management.

## **Content Areas**

- 1. PRINCIPLES** (27-36%)
- 2. ENVIRONMENTAL ISSUES** (11-17 %)
- 3. CODES & REGULATIONS** (7-10 %)
- 4. MATERIALS & TECHNOLOGY** (31-40 %)
- 5. PROJECT & PRACTICE MANAGEMENT** (7-13 %)

## Vignettes

### **ACCESSIBILITY/RAMP**

Design a ramp and stairway connecting two levels that complies with accessibility and code requirements.

### **STAIR DESIGN**

Design a stairway connecting multiple levels that complies with accessibility and code requirements.

### **ROOF PLAN**

Design a sloped-roof plan for the removal of rainwater and locate accessories and equipment.

## KNOWLEDGE / SKILLS

The division has been broken down into a listing of knowledge and skills directly related to each major content area.

### 1. PRINCIPLES (27-36 %)

#### A. Consider

- the impact of human behavior,
- historic precedent, and
- design theory in the selection of systems, materials, and methods on
- Building design and construction.

#### 1. Building Design

#### 2. Design Principles and Design Impact on Human Behavior

#### 3. Building Systems and their Integration

#### 4. Implications of Design Decisions

#### 5. Space Planning and Facility Planning/Management

#### 6. Fixtures, Furniture, Equipment, and Finishes

#### 7. Adaptive Reuse of Buildings and/or Materials

#### 8. Architectural History and Theory

Commented [kn1]:

## 1. PRINCIPLES (27-36 %)

**A.** Consider the impact of human behavior, historic precedent, and design theory in the selection of systems, materials, and methods on building design and construction.

### 1. Building Design

- Develop tasks,
- procedures, and
- methods associated with
- **SD** schematic design and **DD** design development such as
- basic engineering principles,
- spatial visualization and
- modeling.

## 2. Design Principles and Design Impact on Human Behavior

- Assess the effect of form,
- scale,
- color,
- texture,
- ergonomics,
- lighting,
- universal design,
- spatial organization, and
- acoustics in building design
- to meet user needs and client requirements.

### 3. Building Systems and their Integration

- Determine appropriate building systems such as
  - structural,
  - mechanical,
  - electrical, and
  - specialties using basic engineering principles and
  - coordinate these systems into
  - a coherent design that best meets
  - The client's requirements.

## 4. Implications of Design Decisions

- Assess the impact of early design decisions concerning
  - building orientation,
  - area,
  - materials and
  - products selection,
  - cost,
  - code,
  - phasing,
  - future technology changes, and
  - sustainability on the later phases of detailed design,
  - construction, and
  - Building use.
- Now Design a building in Mars!



## 5. Space Planning and Facility Planning/Management

- **SD** Initiate schematic design and
- **DD** design development decisions including
  - spatial visualization and
  - modeling.

## 6. Fixtures, Furniture, Equipment, and Finishes

Assess the selection of

- fixtures,
- furniture,
- equipment, and
- finishes made in
  - SD schematic design and
  - DD design development.

## 7. Adaptive Reuse of Buildings and/or Materials (LEED/Green/...)

Consider the

- constraints,
- issues,
- methods,
- programmatic implications and
- cost impact associated with
  - adaptive reuse of buildings and/or
  - materials during
    - SD schematic design and
    - DD design development phases.

## 8. Architectural History and Theory

Apply concepts of

- architectural history and
- theory in decision making.

## **2 ENVIRONMENTAL ISSUES (11-17 %)**

**A.** Consider the impact of applying principles of sustainable design including

- adaptive re-use,
- thermal and
- moisture protection,
- energy consumption and utilization,
- alternative energy, and
- Hazardous material mitigation to proposed project.

### **1. Hazardous Conditions and Materials**

### **2. Indoor Air Quality**

### **3. Sustainable Design**

### **4. Natural and Artificial Lighting**

### **5. Alternative Energy Systems and New Material Technologies**

## **2 ENVIRONMENTAL ISSUES** (11-17 %)

**B.** Consider the impact of applying principles of sustainable design including adaptive re-use, thermal and moisture protection, energy consumption and utilization, alternative energy, and hazardous material mitigation to proposed project.

### **1. Hazardous Conditions and Materials**

Identify the requirements of

- regulatory agencies and
- their impact on design.
- Survey,
- evaluate, and
- document existing conditions
- related to hazardous materials.
- Develop strategies for mitigation.

## 2. Indoor Air Quality

Develop strategies to ensure indoor air quality.

LEED/Cal Green

Increase ventilation

Etc

### 3. Sustainable Design

Develop designs that

- minimize environmental impact,
- pursues recyclable and replacement strategies,
- considers life-cycle analysis,
- utilizes renewable resources, and
- minimizes material consumption and waste.



## 4. Natural and Artificial Lighting

Develop strategies that utilize

- daylight,
- solar control,
- energy consumption.

## 5. Alternative Energy Systems and New Material Technologies

- Investigate technological advances and
- Innovative building products.

### **3. CODES & REGULATIONS (7-10 %)**

#### **A. Incorporate**

- *building and*
- *specialty codes,*
- *zoning, and*
- *other regulatory requirements for inclusion in*
  - *site design and*
  - *construction.*

## **1. Government and Regulatory Requirements and Permit Processes**

Conduct code analysis to determine compliance with

- government and
- regulatory requirements and
- the permitting processes.

## **2. Specialty Codes and Regulations including Accessibility Laws, Codes and Guidelines**

Conduct analysis of codes and regulations such as

- ADAAG,
- seismic codes,
- life safety,
- Fair Housing Act, and
- historic preservation requirements to incorporate into the
  - site design and
  - construction.

## **4. MATERIALS & TECHNOLOGY (31-40 %)**

Consider impact of design decisions in the selection of systems, materials, and methods on building design and construction.

[Masonry, Metals, Wood, Concrete, others, Specialties]

## **A. MASONRY**

Identify the properties and characteristics of masonry structural and finish materials.

- 1. Building Systems and their Integration**
- 2. Implications of Design Decisions**
- 3. Construction Details and Constructability**
- 4. Construction Materials**
- 5. Product Selection and Availability**
- 6. Cost Estimating, Value Engineering, and Life-Cycle Costing**
- 7. Thermal and Moisture Protection**

## **B. METALS**

Identify the properties and characteristics of structural and miscellaneous metals.

- 1. Building Systems and their Integration**
- 2. Implications of Design Decisions**
- 3. Construction Details and Constructability**
- 4. Construction Materials**
- 5. Product Selection and Availability**
- 6. Cost Estimating, Value Engineering, and Life-Cycle Costing**
- 7. Thermal and Moisture Protection**

## **C. WOOD**

Identify the properties and characteristics of wood structures, rough carpentry, finish carpentry, and millwork assemblies.

### **1. Building Systems and their Integration**

### **2. Implications of Design Decisions**

### **3. Construction Details and Constructability**

### **4. Construction Materials**

### **5. Product Selection and Availability**

### **6. Cost Estimating, Value Engineering, and Life-Cycle Costing**

### **7. Thermal and Moisture Protection**



## **D. CONCRETE**

Identify the properties and characteristics of concrete structures and finishes.

- 1. Building Systems and their Integration**
- 2. Implications of Design Decisions**
- 3. Construction Details and Constructability**
- 4. Construction Materials**
- 5. Product Selection and Availability**
- 6. Cost Estimating, Value Engineering, and Life-Cycle Costing**
- 7. Thermal and Moisture Protection**

## **E. OTHER**

Identify the properties and characteristics of miscellaneous systems, assemblies, membranes, cladding, coatings, and finish materials (e.g., plastics, composites, glass, tensile, pneumatic, EIFS, etc.).

### **1. Building Systems and their Integration**

### **2. Implications of Design Decisions**

### **3. Construction Details and Constructability**

### **4. Construction Materials**

### **5. Product Selection and Availability**

### **6. Cost Estimating, Value Engineering, and Life-Cycle Costing**

### **7. Thermal and Moisture Protection**

## **F. SPECIALTIES**

Analyze and select accessories, equipment, and fittings.

- 1. Building Systems and their Integration**
- 2. Implications of Design Decisions**
- 3. Construction Details and Constructability**
- 4. Construction Materials**
- 5. Product Selection and Availability**
- 6. Cost Estimating, Value Engineering, and Life-Cycle Costing**
- 7. Thermal and Moisture Protection**
- 8 Natural and Artificial Lighting**

## 5. PROJECT & PRACTICE MANAGEMENT (7-13 %)

Ascertain the impact of

- construction sequencing,
- scheduling,
- cost, and
- risk management on the selection of
  - systems,
  - materials, and
  - methods.

**A. Determine the impact of construction**

- sequencing,
- scheduling,
- cost, and
- risk management on selection of
  - systems,
  - materials, and
  - methods.

### 1. Construction Sequencing

Prepare **phasing plans** for building design and construction.

### 2. Cost Estimating, Value Engineering, and Life-Cycle Costing

Develop and revise **cost estimates** for building design and construction through the design development phase.

### 3. Project Schedule Management **Manage**

- the building design and
- construction schedule of professional services and document project progress

via **contract document**

- setup,
- storyboarding, and
- staffing projections.

### 4. Risk Management

- Assess building design and construction professional and general liability and
- risk management procedures, phasing, budget, and schedule.

## MULTIPLE-CHOICE QUESTIONS

### Toilet Partitions



#### Powder Coated Steel

General's Powder Coated galvanized-Bonderized Steel is available in all styles for toilet partitions, showers, and dressing compartments. The exclusive use of galvanized-bonderized steel provides additional protection while enhancing paint adhesion. The finish is a superior quality powder coated Hybrid Epoxy – polyester applied electrostatically, and baked until fully cured. [view details »](#)



#### Stainless Steel

General's exclusive use of stainless steel polished to a satin finish offers the ultimate in toilet partitions. The finish is protected in the manufacturing process and in shipping by aP.V.C. film which is removed at the time of installation. Scratches can be removed, and the original beauty restored by buffing. Also available with a deep textured surface, or powder coated. [view details »](#)

*Absoluteco.com*

*Greenerade.com*

*Saum Greenerade @facebook*

*Endlesschool.com*



### Plastic Laminate

Toilet partitions manufactured in our plastic laminate line utilizes High Pressure laminates that meet or exceed NEMA standards. Standard core is particleboard and not recommended for high moisture areas. For high moisture areas, Solid Phenolic Core or High Density Polymer should be used. [view details »](#)



### Solid Phenolic Core

Solid Phenolic toilet partitions are composed of melamine impregnated decorative surface papers superimposed over a varying number of Kraft phenolic core sheets to achieve a desired thickness, forming a one piece panel which will not delaminate. [view details »](#)

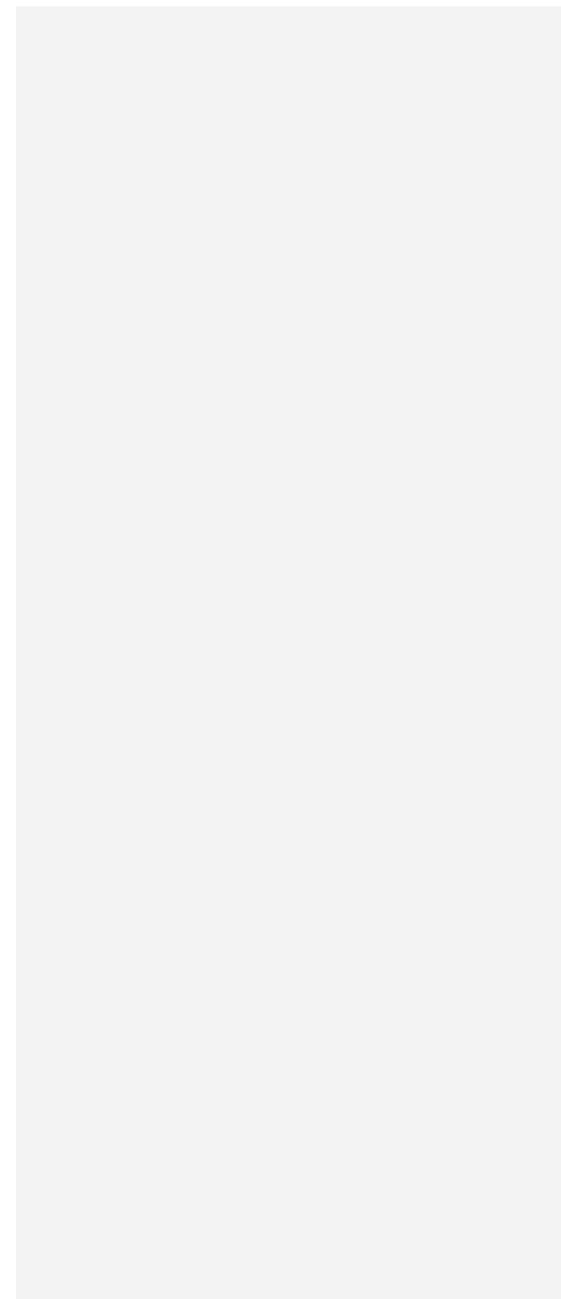



### High Density Polymer

General's H.D.P. toilet partitions, showers, and dressing compartments are manufactured using high-density polymer resin. Color is solid throughout. Compartments can not rust, rot, delaminate, or absorb odors. [view details »](#)

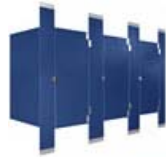

### Fiberglass Reinforced

General's F.R.P. is a highly durable toilet partition system with a resin rich surface that is tough and easy to clean. Bonded to solid 90% wood substrate core manufactured with phenolic resins for moisture resistance. Virtually 100% of our wood supply comes from managed forestlands and all materials we use would either be burned or go to waste. [view details »](#)



### Color-Thru Phenolic Toilet Partitions

Color-Thru Solid Phenolic Core Panels offer all the strength and durability of our black core phenolic, with the added advantage of consistent matching color throughout the core, forming a one piece panel which will not delaminate. [view more »](#)

1. Which of the following toilet partition finishes has the LOWEST initial cost?

- Baked enamel
- Laminated plastic
- Stainless steel
- Porcelain enamel

## Roof Flashing

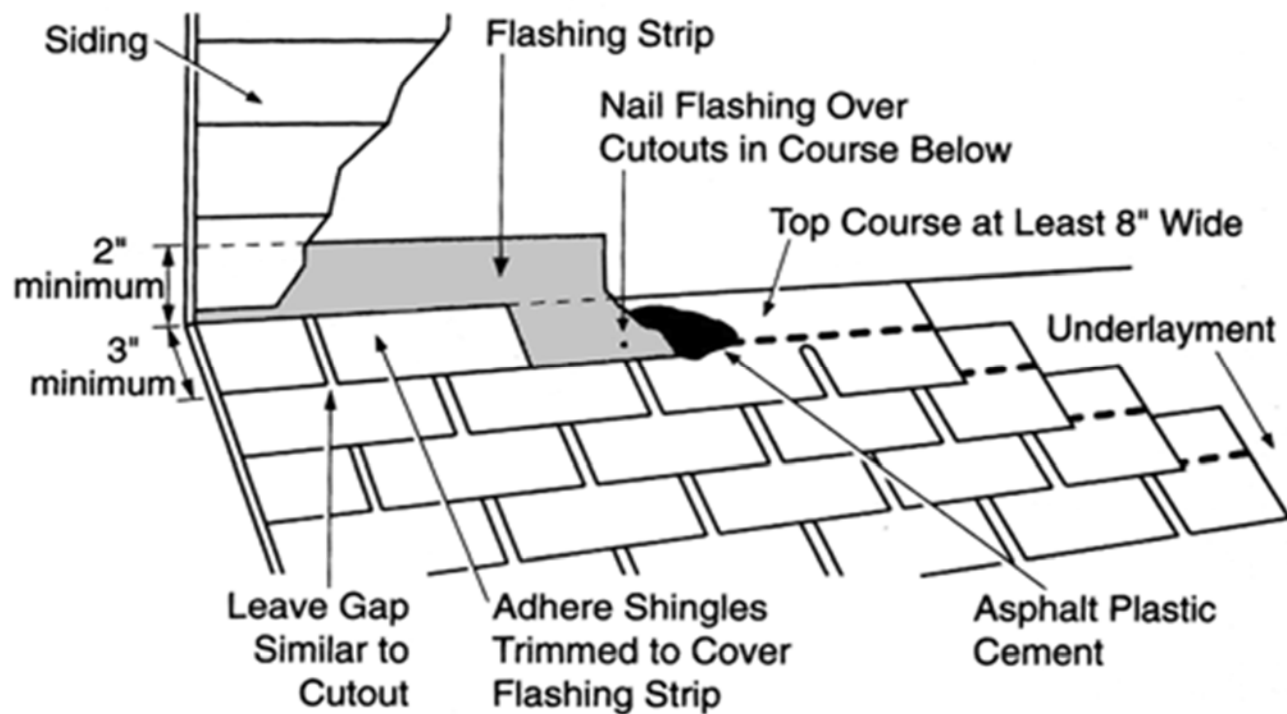

## Overview: Essential Knowledge

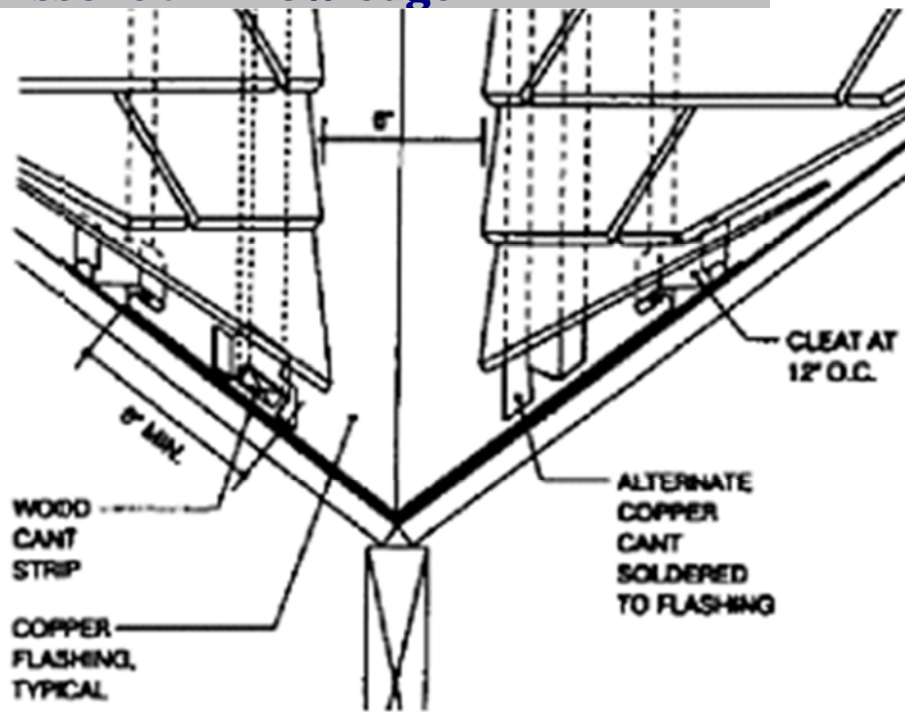

Residential roofing is typically made up of a multitude of materials and surfaces whose primary task is to maintain a barrier between the interior and the weather. The most pervasive and difficult weather element to control is water. Roof flashing is usually the last line of defense in the battle against water penetration.

Flashing forms the intersections and terminations of roofing systems and surfaces, to thwart water penetration. The most common locations for roof flashing are at valleys, chimneys, roof penetrations, eaves, rakes, skylights, ridges, and at roof-to-wall intersections.

Flashing must be configured to resist the three mechanisms of water penetration: gravity, surface tension, and wind pressure. To achieve this, flashing can be lapped shingle style, soldered or sealed to function as a continuous surface, or can be configured with a non-continuous profile to defeat water surface tension.

Flashing materials must be durable, low in maintenance requirements, weather resistant, able to accommodate movement and be compatible with adjacent materials. Common modes of failure include exposure to salt air, excessive heat, acid rain, heavy snows, and scouring winds.

Traditional materials and methods of installing flashing produce some of the longest lasting of building systems components. Those methods do, however, require experience and are time consuming.

Newer membrane materials and modern sealants are available that complement time-tested techniques, but, regardless of the methods and materials employed, the basic principles of roof flashing must still be adhered to, and the three water penetration mechanisms must be overcome.

## Valley Details: A Visual Primer

### A) OPEN VALLEY

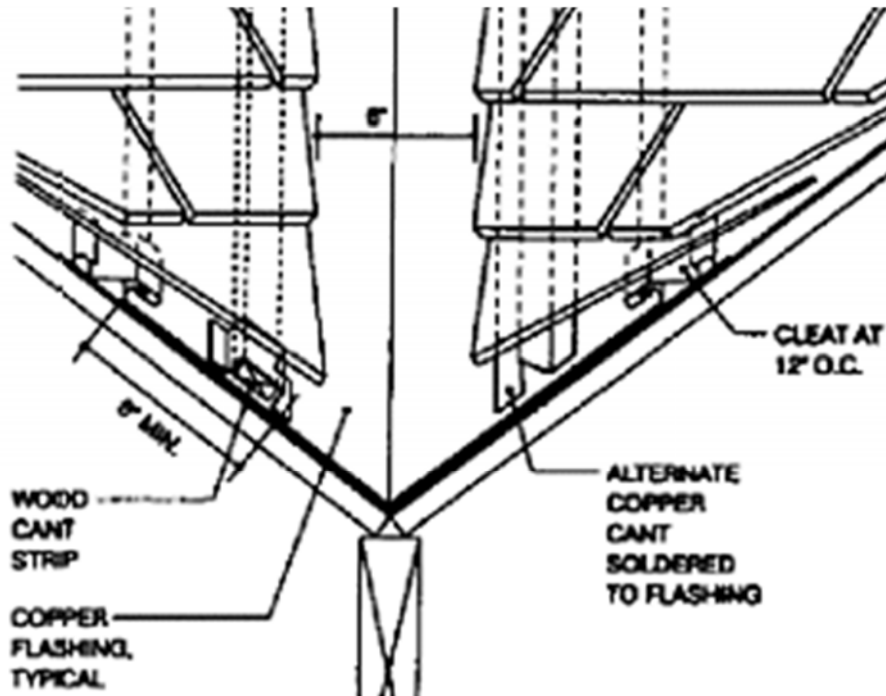

The detail shows a typical open flashing for a shingle or slate roof. Two different cants are illustrated. The cant strip can also be constructed as shown in Detail D. The shingles or slate must lap the flashing at least 6 inches.

## **B) EQUAL SLOPES, UNEQUAL WATER FLOW**

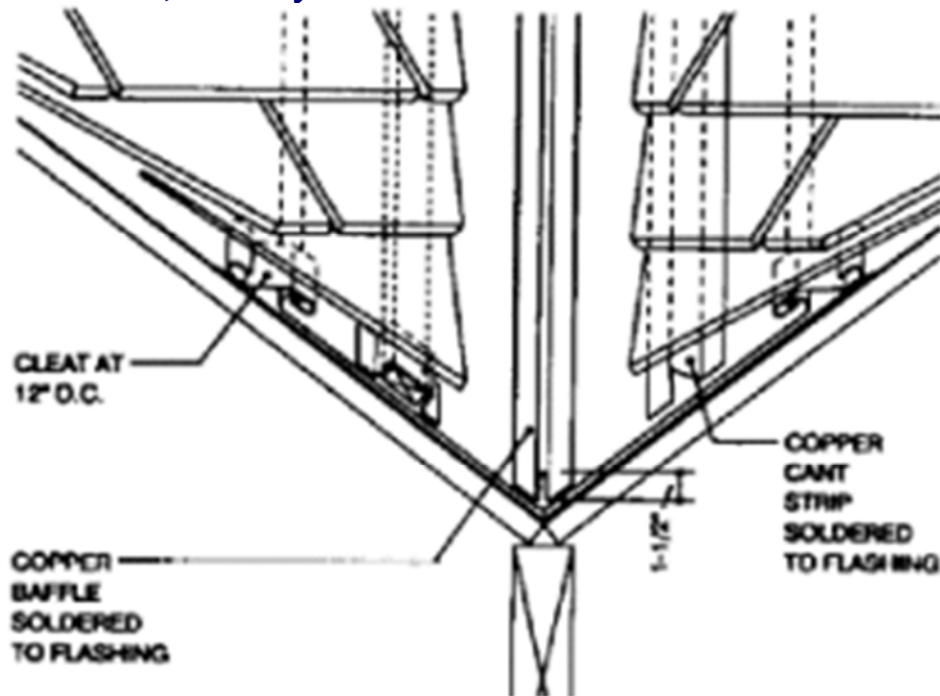

Where unequal water flow is expected, a baffle, 1 1/2 inches high, should be installed as shown to prevent water of higher velocity from forcing its way past the opposite edge of the valley flashing. The baffle can also be constructed as shown in Detail D.

## ***C) CLOSED VALLEY***

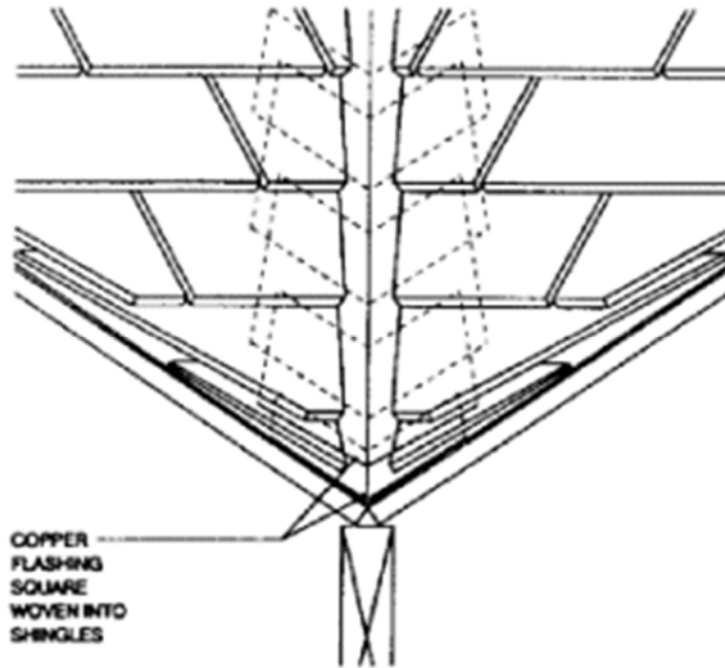

Intersecting roofs using a closed valley must have the same slopes so that the shingle butts line up at the valley intersection. For roof pitches of 6" or more per foot the flashing extends at least 9" under the roof covering on each side. For roof pitches less than 6 inches per foot the flashing extends at least 12 inches.



## D) UNEQUAL SLOPES

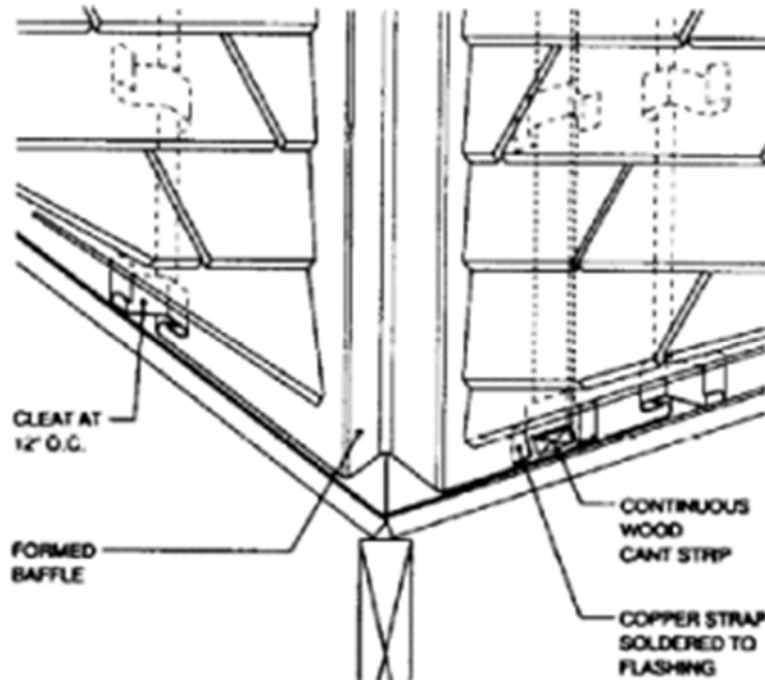

This condition requires a baffle for the same reason as Detail B. it can be constructed as shown in either detail. This detail also shows a different cant strip. Other methods of raising the shingles away from the copper are shown in Details A and B.

## Roof Crickets

<http://www.youtube.com/watch?v=xG6M0yPWJG0>

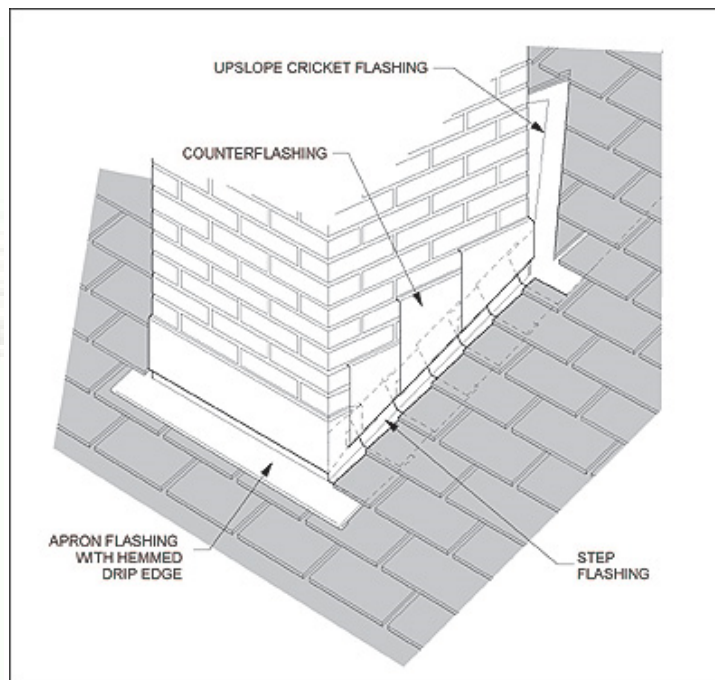
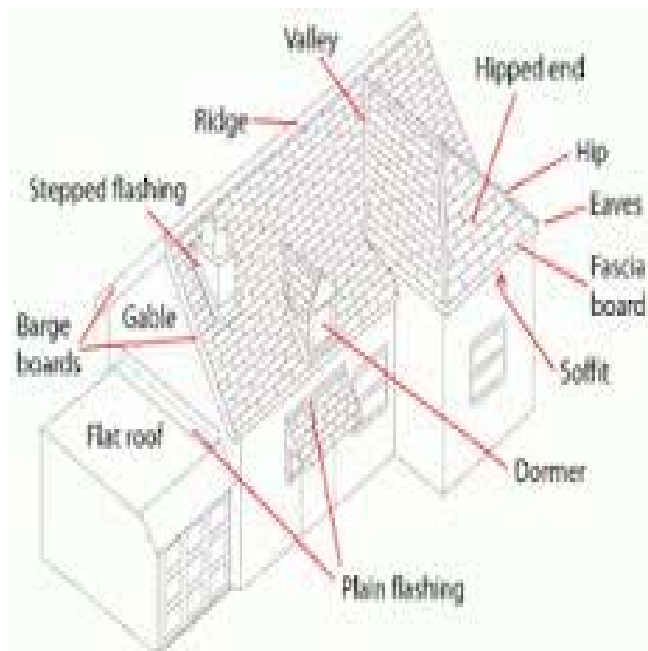

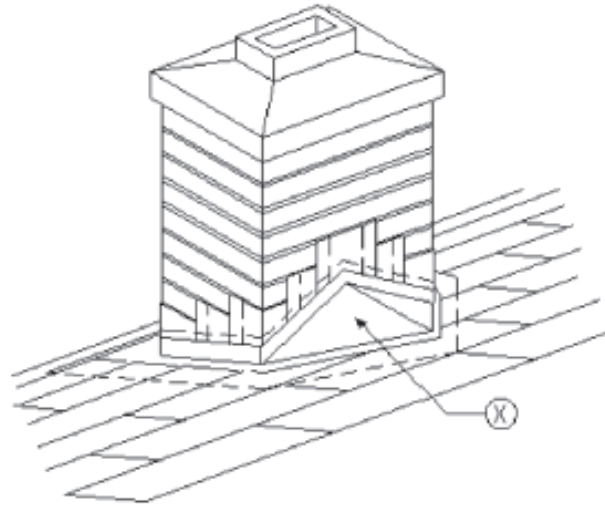

3. What is shown at X in the drawing above?

- A cricket
- Base flashing
- Cap flashing
- Gable flashing

**(Copper & Aluminum mixed on a chimney flashing - WRONG!)**

We are seeing many complaints resulting from roofers using aluminum base flashings and covering with copper counter flashings. This is sold as a "Copper Flashing," and the aluminum wears and deteriorates quickly.

We are also seeing mixed metals in the fasteners where galvanized nails are used to fasten copper roofing cleats. Some newcomers to the trade scoff at what is a basic physics lesson in metals usage.

So, never mix metals! Or, at least be very careful and check the Galvanic Scale before you even think of mixing metals. Copper and Aluminum are 7 positions away from each other on the basic Galvanic Scale! (See below)



## Fundamentals: Architectural Considerations

### Weathering, Corrosion, Staining, Substrate, Solder, Sealants

One of the most important issues concerning the use of copper is the chemical reaction between copper and other materials. Chemical reactions are responsible for corrosion, staining, and even the green patina that develops on copper surfaces over time.

#### Weathering and Patination:

The oxidation process that gives copper its characteristic green patina is a result of exposure to an acidic atmosphere. The process is, therefore, faster in some metropolitan, marine, and industrial areas, where higher concentrations of pollutants exist. When acidic moisture comes in contact with exposed copper surfaces, it reacts with the copper to form copper sulfate. The acid is neutralized during the reaction with the copper. This patina eventually covers the surface and adheres tightly to it, thus providing a protective layer against further weathering.

#### Corrosion:

All metals have a property called nobility. It is a measure of a metal's resistance to corrosion when in contact with another metal. A greater relative difference in nobility between the two metals in contact indicates a greater corrosion potential. **Table 1.1.4** ranks the most common metals used in construction in increasing nobility, called the galvanic number.

**Table 1.1.4 - The Nobility of Common Metals**

1. Aluminum
2. Zinc
3. Steel
4. Iron
5. Stainless Steel - Active
6. Tin
7. Lead
8. Copper
9. Stainless Steel - Passive

When dissimilar metals are in contact with one another in the presence of an electrolyte, galvanic action occurs, resulting in the deterioration of the metal with the lower galvanic number. The electrolyte may be rain water running from one surface to another, or moisture from the air containing enough acid to cause it to act as an electrolyte.

Since copper has one of the highest galvanic numbers or nobility of the active metals, it will not be harmed by contact with any of them. It will, however, cause corrosion of the other metals if in direct contact. The solution is to prevent such direct contact with the use of separating materials, such as specific paints or gaskets.

It is not necessary to isolate copper from lead, tin or stainless steel under most circumstances. The principal metals of concern in terms of direct contact are aluminum and zinc.

If paints or coatings are used for isolation, they must be compatible with both metals. Bituminous or zinc chromate primers can be used between copper and aluminum. Either of these or a red lead primer can be effective in separating copper from iron and other ferrous metals.

Taping or gasketing with nonabsorptive materials or sealants are effective methods of separating copper from all other metals. In areas with severe exposure, lead or similar gasketing materials should be used, except between copper and aluminum.

Regardless of the method used to separate the metals, wash from copper surfaces should be prevented from draining onto exposed aluminum. Traces of copper salts in the wash may accelerate corrosion of the aluminum.

Another type of corrosion, which affects copper, is caused by the flow of acidic water concentrated on a small area of copper. This type, often called "erosion corrosion", occurs **when rain falls on a non-copper roof such as tile, slate, wood, or asphalt**. The acidic water is not neutralized as it flows over the inert material. When water, collected over a large surface, is diverted or collected by a relatively small copper flashing or gutter, the copper may deteriorate before it develops a protective patina. Another type of corrosion occurs at the drip edge of inert roofing material conducting water into a copper gutter or valley. **If shingles rest directly on the copper, the corrosive effect is amplified because moisture is held along the edge by capillary action resulting in "line-corrosion"**. The solution is to raise the lower edge of the shingles with a cant strip, or to provide a replaceable reinforcing strip between the shingles and the copper.

## **Staining:**

The wash of water over copper surfaces can have additional impact. Moisture in contact with copper surfaces tends to pick up small quantities of copper salts. When this moisture contacts porous material, such as marble or limestone, it is absorbed. As the moisture evaporates, it leaves behind the copper salts as a stain on these materials. The green stain is particularly visible on light colored surfaces.

The condition does not occur with heavy rains or similar rapid run-off, since the dwell time of the moisture on the copper is short and little copper salt is picked up. Staining results from the slow bleeding action of copper laden moisture.

There are a number of ways to reduce staining or its visual impact. Two common methods are: collecting run-off in gutters and directing it away from the building via downspouts; and designing drip edges to a minimum of one inch, helping reduce the amount of copper laden moisture that comes into contact with material below. Coating the adjacent surface of the porous material with a clear silicone sealant can reduce staining by minimizing the amount of moisture absorbed into the surface. The use of lead-coated copper results in a black or gray stain, which may blend better with some building materials.

## **Substrate Selection:**

The preparation of the substrate onto which copper will be applied depends in part on the substrate selected and the copper application. A number of considerations, however, must always be taken into account.



In selecting the substrate, a key consideration is the method of attachment of the copper. All applications that rely on nails or screws to attach the copper or cleats to the underlying structure require a nailable deck, nailing strips within the deck, or wood blocking at specific locations. Such applications include standing seam roofs, batten seam roofs, flat seam roofs, continuous edge strips and cleats, and flashings around roof penetrations.

Regardless of the attachment method used, the structural integrity of the substrate should not be compromised. It must be able hold the roof under sustained design wind conditions, as well as to conform to all other required codes and standards.

The most common substrate for copper is wood, usually 1/2" to 3/4" plywood. Lumber should be kiln-dried and laid with all joints true and even to provide a smooth surface. It is recommended that wood be allowed to weather for a few days after installation. During this period it should be protected from rain, allowing it to conform to atmospheric temperature and moisture level, while settling into place.

There have been many recent developments in fire retardant treated (FRT) plywood and lumber. Most of these products use wood or plywood that is pressure-impregnated with chemical salts in water solution to inhibit combustion. Many of these salts are corrosive to copper, as well as other metals and materials. If leaching of these salts brings them into contact with the copper, corrosion will occur. This is particularly likely in areas with high humidity, if condensation occurs, or if water is introduced during construction or at a later time. Any areas where salt laden moisture can collect then evaporate, thereby increasing the concentrations of salts, will accelerate the corrosion process. For a complete and updated report on Fire Rated Plywood and Corrosion contact CDA.

Other materials used as substrates for copper include: concrete, brick, masonry units, terra cotta, and stucco. The guidelines discussed above apply to these materials as well. Smooth, dry surfaces, compatibility with copper, and provision for fasteners are all required for an acceptable substrate.

### **Substrate Preparation:**

Sheet and strip copper applications in construction are inevitably required to provide some level of resistance to water penetration. Anything that can cause punctures or openings in the copper membrane should be avoided. Copper roofs, valley flashings, and gutter linings should always be applied on a smooth, dry, stable surface with no projecting nail heads or other imperfections. Movement in the substrate should be accommodated by properly designed expansion joints.

In such applications, an approved underlayment, usually saturated felt, must be applied to the substrate. The felt acts as a cushion for the copper sheets. A sheet of rosin-sized building paper should be inserted between the copper and the underlayment. This will prevent bonding between the two surfaces that would otherwise restrict the thermal movement of the copper. The only exceptions to this requirement are applications where the copper is not intended to move, not even under thermal stress. For example, continuous cleats and edge strips are nailed down, usually in a staggered pattern of nails 3 inches on center, to limit movement.

### **Solder and Sealants:**

Copper construction methods have traditionally relied on solder to ensure water-tightness and to strengthen joints and seams. The solder used is common 50-50 tin-lead bar solder for uncoated copper, and 60-40 tin-lead for lead-coated copper. It is typically applied to mechanically fastened

or formed, rigid joints. Soldered seams and joints are permanent; they should last the life of the copper. Continuous, long runs of soldered seams should be avoided to limit stress fractures.

In the weathering process, the lead contained in solder turns gray. Exposed solder in the finished joints can be minimized with the use of blind soldering. In this technique, solder is applied to the back or concealed edge of copper surfaces.

An alternative to solder, where its additional strength is not required, is the use of sealants. Sealant filled joints have been used successfully for standing seam and batten seam roofing applications where roof slopes are less than three inches per foot. Sealants can also be used in joints that are primarily designed to accommodate thermal movement of the copper.

The sealants used should be tested by the manufacturer and designated as compatible for use with copper. Many elastomeric polyurethane, silicone, butyl, polysulfide or other inorganic or rubber based sealants have shown acceptable performance. Acrylic, neoprene, and nitrile based sealants have been observed to actively corrode copper. The use of such sealants is, therefore, not recommended.

## ARE Forum

- The tannic acid in red cedar has a corrosive effect on copper and galvanized fasteners.
- (Similarly, the tannic acid in red oak can have a corrosive effect on iron fasteners.)
- A galvanic reaction is caused by a metal to metal interaction and deals only with this.
- What is happening here is similar to acid washing copper to induce a patina quickly except that the copper is constantly being exposed to the acid being leached out of the shingles due to water.
- Lead -coated copper could be used with red cedar shingles and stainless steel fasteners for attaching any red cedar or redwood trim.

4. To prevent it from deteriorating, copper should be isolated from direct contact with which of the following roofing materials?

- o Asphalt shingles
- o **Red-cedar shingles**
- o Built-up roofing
- o Mineral-fiber felts

## True

- A high visible light transmission value indicates that more light can pass through.- Hole is larger
- **Visible Transmittance (VT or Tvis)**
- Visible transmittance: is the amount of light in the visible portion of the spectrum that passes through a glazing material. A higher VT means there is more daylight in a space which, if designed properly, can offset electric lighting and its associated cooling loads. Visible transmittance is influenced by the glazing type, the number of panes, and any glass coatings. Visible transmittance of glazing ranges from above 90% for uncoated water-white clear glass to less than 10% for highly reflective coatings on tinted glass. A typical double-pane IGU had a VT of around 78%. This value decreases somewhat by adding a low-E coating and decreased substantially when adding a tint (see figure to the right). VT values for the whole window are always less than center-of-glass values since the VT of the frame is zero.

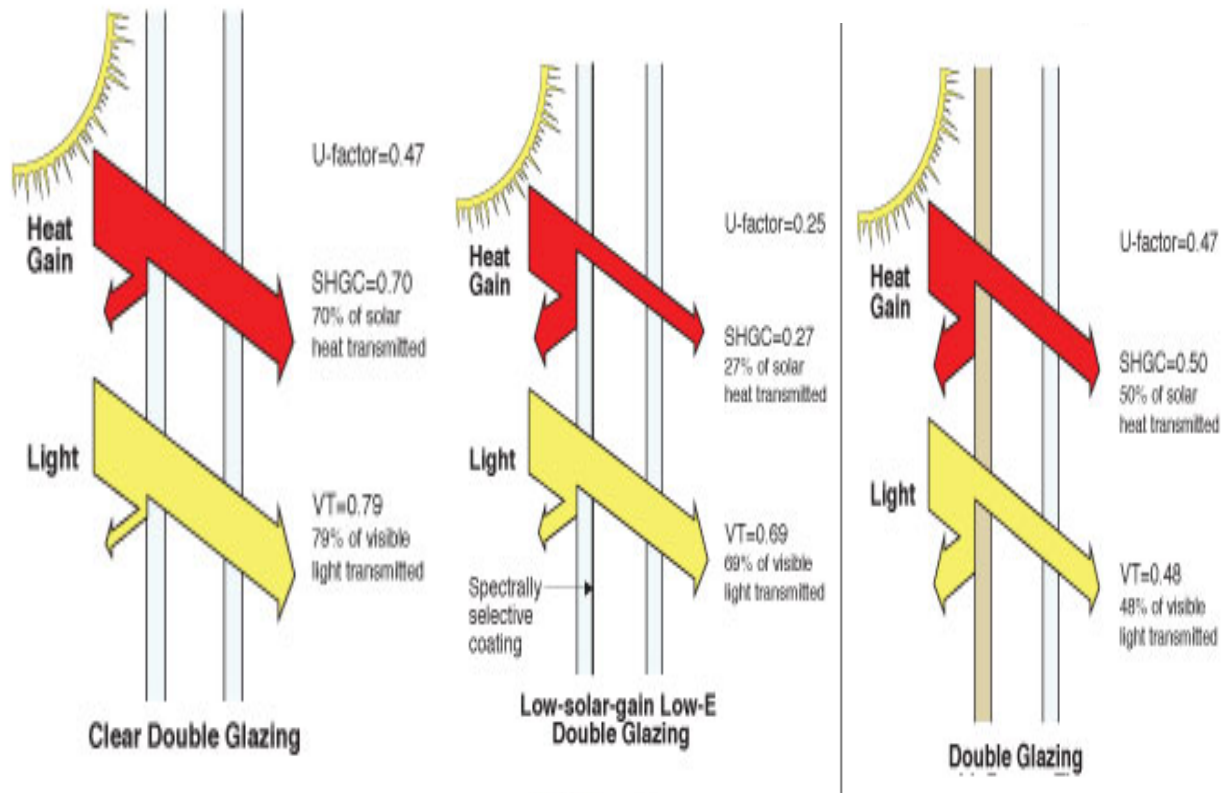

- A low heat transfer coefficient indicates better thermal value

#### U-Value Rating

The U-Value of a window measures its capacity to decrease heat that is lost through indirect exposure to radiation. This means, for example, the heat loss that occurs in the winter time in seasonal climate zones. With a lower U-Value, less heat loss will occur from inside the home. This translates to reduced heating bills.

A low U-Value is among the key indicators of energy efficiency since many communities are increasingly following the International Residential Code for 2006. This code requires all exterior doors and energy efficient windows to hold a U-Value of .40 or higher. Premium energy efficient windows on the market today can have U-Values ranging from .22 up through .30.

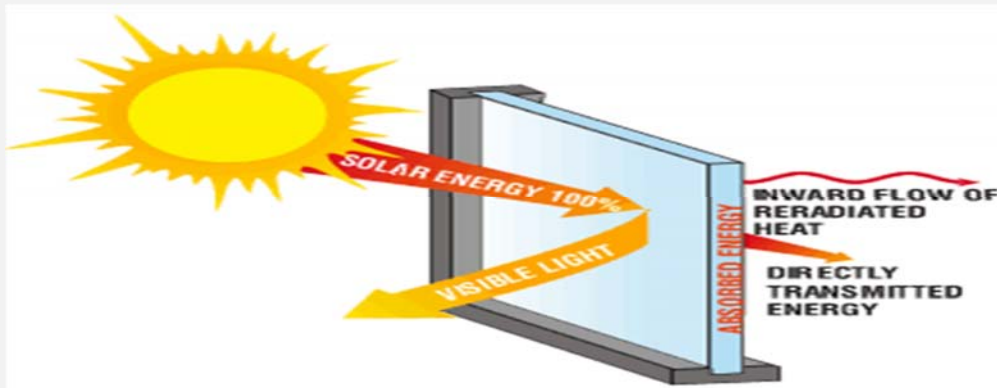



- A low solar heat gain coefficient value indicates that less heat is transmitted.

### **Solar Heat Gain Coefficient (SHGC) Rating**

This rating indicates a window's capability to decrease the heat gained as a result of direct radiation. An example of this is when sunlight comes through the windows in the summertime in hotter climate zones. The lower the SHGC rating is, the less the amount of heat that is being taken into the home. This results in decreased cooling expenses.

**Not: A high air leakage rate value indicates a tighter seal.**

5. All of the following are true when selecting windows for a building

EXCEPT:

- o A high visible light transmission value indicates that more light can pass through.
- o **A high air leakage rate value indicates a tighter seal.**
- o A low solar heat gain coefficient value indicates that less heat is transmitted.
- o A low heat transfer coefficient indicates better thermal value.

## Need for Panic Hardware



**Panic Hardware:** provide easy release of the latch on the door

**Contemporary Touchbar** Designed for today's demanding architectural requirements. Finely machined parts ensure smooth, easy touchbar operation; rugged components provide the durability needed to withstand heavy usage.

**Traditional Touchbar** Proven durability in a traditional crossbar-style device. Heavy-duty components machined to fine tolerances. Simple installation, consistent reliability and security, minimal maintenance.

**Economical Touchbar** Solid steel components deliver consistent, dependable performance across an array of applications. Available with a variety of attractive trim options and durable powder-coated finishes.

## 2. The primary purpose of panic hardware on exit doors is to

- o allow an alternate method of opening the door
- o allow easier access for disabled occupants
- o provide a method of controlling exit doors
- o provide easy release of the latch on the door**

**Here are the applicable excerpts from the 2009 International Building Code:**

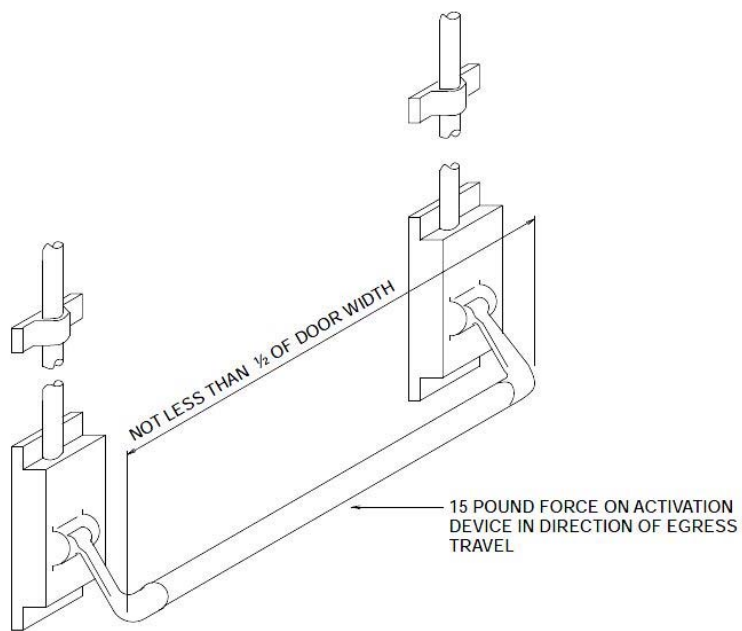

Graphic: 2009 International Building Code Commentary

*1008.1.10 Panic and fire exit hardware. Doors serving a Group H occupancy and doors serving rooms or spaces with an occupant load of 50 or more in a Group A or E occupancy shall not be provided with a latch or lock unless it is panic hardware or fire exit hardware.*

*Exception: A main exit of a Group A occupancy in compliance with Section 1008.1.9.3, Item 2.*

*Electrical rooms with equipment rated 1,200 amperes or more and over 6 feet (1829 mm) wide that contain overcurrent devices, switching devices or control devices with exit or exit access doors shall be equipped with panic hardware or fire exit hardware. The doors shall swing in the direction of egress travel.*

*1008.1.10.1 Installation. Where panic or fire exit hardware is installed, it shall comply with the following:*

- 1. Panic hardware shall be listed in accordance with UL 305;*
- 2. Fire exit hardware shall be listed in accordance with UL 10C and UL 305;*
- 3. The actuating portion of the releasing device shall extend at least one-half of the door leaf width; and*
- 4. The maximum unlatching force shall not exceed 15 pounds (67 N).*

*1008.1.10.2 Balanced doors. If balanced doors are used and panic hardware is required, the panic hardware shall be the push-pad type and the pad shall not extend more than one-half the width of the door measured from the latch side.*

**Note:** NFPA 101 – The Life Safety Code has not changed the threshold for occupant load in regard to panic hardware as of the 2009 edition, so the 100-occupant figure still applies to projects where NFPA 101 is being enforced. The requirements for High Hazard occupancies also differ between NFPA 101 and the IBC, so consult the pertinent code for more information.

Some state and local jurisdictions have modified the IBC requirements, so check the codes used in the applicable jurisdiction

6. Which of the following occupancy classifications requires panic hardware at the required exits?

- o Manufacturing facility
- o Motel guest room
- o Movie theater**
- o High-rise office suite



## **ADA Ramp Codes : RAMP CODES 4.8\***

### **4.8.1 General**

Any part of an accessible route with a slope greater than 1:20 shall be considered a ramp and shall comply with 4.8.

### **4.8.2 Slope and Rise.**

The least possible slope shall be used for any ramp. The maximum slope of a ramp in new construction shall be 1:12. The maximum rise for any ramp run shall be 30 inches. Curb ramps and ramps to be constructed on existing sites or in existing buildings or facilities may have slopes and rises, if space limitations prohibit the use of a 1:12 slope or less.

### **4.8.3 Clear Width**

The minimum clear width of a ramp shall be 36 inches.

### **4.8.4 Landings**

Ramps shall have level landings at the bottom and top of each run. Landings shall have the following features:

1. The landing shall be at least as wide as the widest ramp run leading to it.
2. The landing length shall be a minimum of 60 inches clear.
3. If ramps change direction at landings, the minimum landing size shall be 60 in. x 60 in.
4. If a doorway is located at a landing, then the area in front of the door shall comply with 4.13.6.

### **4.13.6 Maneuvering Clearances at Doors**

Minimum maneuvering clearances at doors that are not automatic or power assisted shall be as shown in Fig 25 (next page). The floor or ground area within the required clearances shall be level and clear.

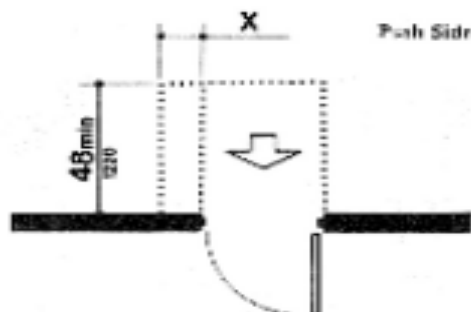
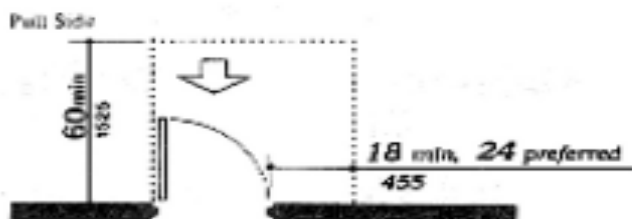

NOTE:  $x = 12$  in (305 mm) if door has both a closer and latch.

(a) Front Approaches — Swinging Doors

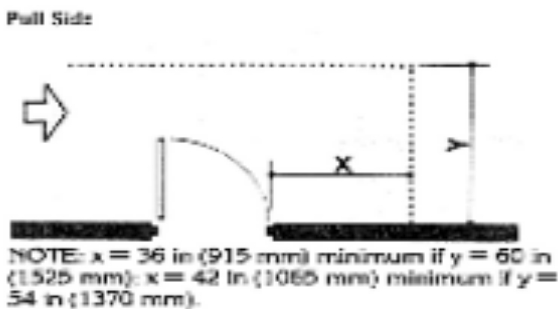

NOTE:  $x = 36$  in (915 mm) minimum if  $y = 60$  in (1525 mm);  $x = 42$  in (1065 mm) minimum if  $y = 54$  in (1370 mm).

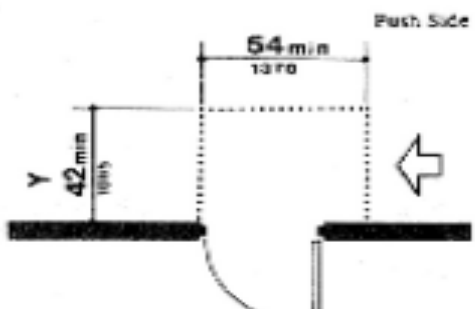

NOTE:  $y = 48$  in (1220 mm) minimum if door has both a latch and closer.

(b) Hinge Side Approaches — Swinging Doors

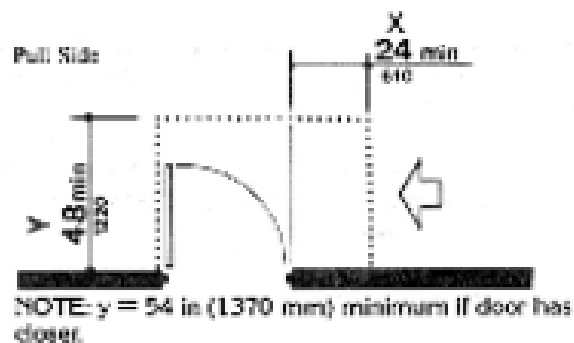

NOTE: y = 54 in (1370 mm) minimum if door has closer.

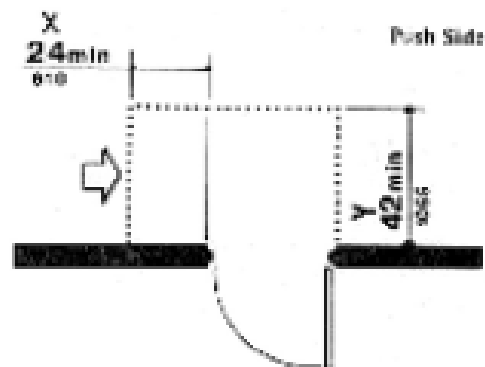

NOTE: y = 48 in (1220 mm) minimum if door has closer.

(c) Latch Side Approaches — Swinging Doors

NOTE: All doors in alcoves shall comply with the clearances for front approaches.

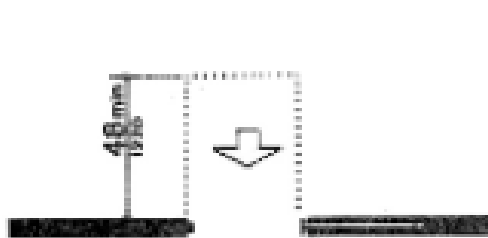

(d) Front Approach — Sliding Doors and Folding Doors

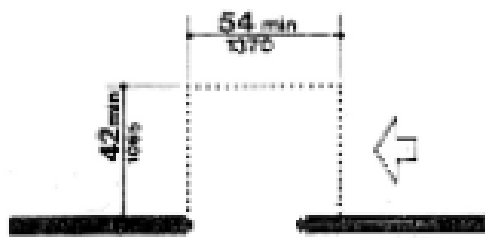

(e) Side Side Approach — Sliding Doors and Folding Doors

#### **4.8.5 Handrails**

If a ramp run has a rise greater than 6 inches or a horizontal projection greater than 72 inches, then it shall have handrails on both sides. Handrails are not required on curb ramps. Handrails shall have the following features.

1. Handrails shall be provided along both sides of ramp segments. The inside handrail on switchbacks or dogleg ramps shall always be continuous.
2. If handrails are not continuous, they shall extend at least 12 inches beyond the top and bottom of the ramp segment and shall be parallel with the floor or ground surface.
3. The clear space between the handrail and the wall shall be 1 1/2 inches. Handrails may be located in a recess if the recess is a maximum of 3 inches deep and extends at least 18 inches above the top of the rail.
4. Gripping surfaces shall be continuous, without interruption by newel posts, other construction elements, or obstructions.
5. The diameter or width of the gripping surface of a handrail shall be 1 1/4 inches to 1 1/2 inches or the shape shall provide an equivalent gripping surface.
6. The top of the handrail gripping surfaces shall be mounted between 34 inches and 38 inches above ramp surfaces.
7. A handrail and any wall or other surface adjacent to it shall be free of any sharp or abrasive elements. Edges shall have a minimum radius of 1/8 inch.

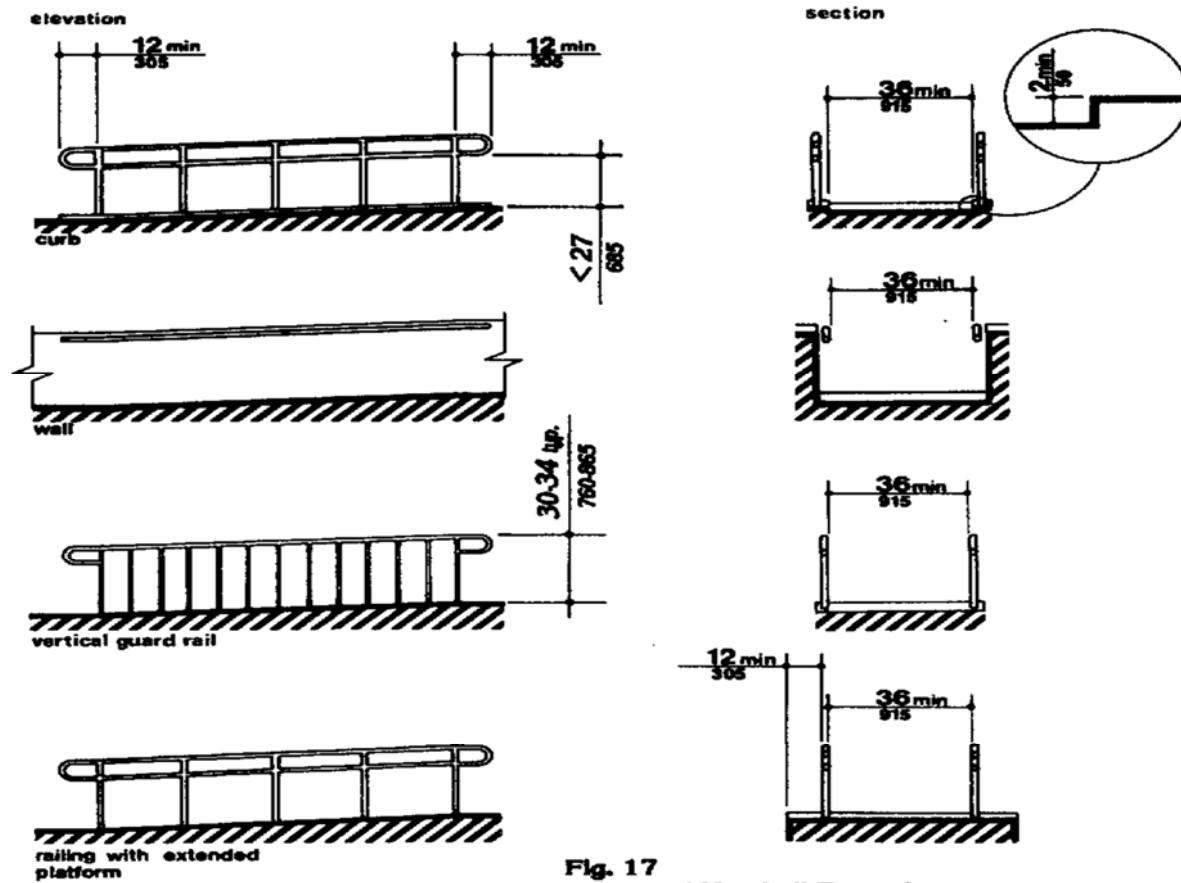

Fig. 17  
Examples of Edge Protection and Handrail Extensions

#### **4.8.6 Cross slope and Surfaces**

The cross slope of ramp surfaces shall be no greater than 1:50. Ramp surfaces shall comply with 4.5.

#### **4.5.1 General**

Ground and floor surfaces along accessible routes and in accessible rooms and spaces including floors, walks, ramps, stairs, and curb ramps shall be stable, firm, slip resistant, and shall comply with 4.5.

#### **4.8.7 Edge Protection**

Ramps and landings with drop-offs shall have curbs, walls, railings, or projection surfaces that prevent people from slipping off the ramp. Curbs shall be a minimum of 2 inches high.

#### **4.8.8 Outdoor Conditions**

Outdoor ramps and their approaches shall be designed so that water will not accumulate on walking surfaces.

7. Accessible ramp handrails shall extend beyond the top and bottom of the ramp a minimum of

- o 6 in
- o 9 in
- o 12 in
- o 15 in

Water Closets for an Assembly Occupancy

Number of Persons of Each Sex	Minimum Number of Water Closets	
	Male	Female
1 - 50	1	2
51 - 75	2	3
76 - 100	2	4
101 - 125	3	5
126 - 150	3	6
151 - 175	4	7
176 - 200	4	8
201 - 250	5	9
251 - 300	5	10
301 - 350	6	11
351 - 400	6	12
Over 400	7 plus 1 for each additional increment of 200 males in excess of 400	13 plus 1 for each additional increment of 100 females in excess of 400



8. Based on the table above, the minimum number of water closets required for women in a theater with a seating capacity of 4,000 is

4000/2= 2000 Male, 2000 Female for over 400:  
13 + 1 per increment of 100

Up to 401	Needs 13	
2000 – 401 = 1599/100= 15.99 or 16		16
	<u>29</u>	

What about the Male?

A **vapor barrier** (or **vapour barrier**) is often used to refer to any material for [damp proofing](#), typically a plastic or foil sheet, that resists diffusion of moisture through wall, ceiling and floor assemblies of buildings and of [packaging](#). Technically, many of these materials are only **vapor retarders** as they have varying degrees of [permeability](#).

Materials have a [moisture vapor transmission rate](#) that is established by standard test methods. One common set of units is g/m<sup>2</sup>·day or g/100in<sup>2</sup>·day. Permeability can be reported in [perms](#), a measure of the rate of transfer of water vapor through a material (1.0 US perm = 1.0 grain/square-foot·hour·[inch of mercury](#) ≈ 57 SI perm = 57 ng/s·m<sup>2</sup>·Pa). American building codes have classified vapor retarders as having a water vapor permeance of 1 perm or less when tested in accordance with the ASTM E96 desiccant, or dry cup method.<sup>[1]</sup> Vapor retarding materials are generally categorized as:

- *Impermeable* (≤1 US perm, or ≤57 SI perm) (Materials such as asphalt-backed kraft paper, vapor-retarding paint, oil-based paints, vinyl wall coverings, extruded polystyrene, plywood, OSB),
- *Semi-permeable* (1-10 US perm, or 57-570 SI perm) (Materials such as unfaced expanded polystyrene, fiberfaced isocyanurate, heavy asphalt-impregnated building papers, some latex-based paints),
- *Permeable* (>10 US perm, or >570 SI perm) (Materials such as unpainted gypsum board and plaster, unfaced fiber glass insulation, cellulose insulation, unpainted stucco, cement sheathings, spunbonded polyolefin or some polymer-based exterior air barrier films).

### Vapor Barrier Placement By Geographical Location

In most cold climates, vapor barriers should be placed on the interior (warm-in-winter) side of walls. However, the map shows that in some southern climates, the vapor barrier should be omitted, while in hot and humid climates, such as along the Gulf coast and in Florida, the vapor barrier should be placed on the exterior of the wall.



### Perm Ratings of Different Materials (Rating of 1 or less qualifies as a vapor barrier)

Asphalt-coated paper backing on insulation	0.40
Polyethylene plastic (6 mil)	0.06
Plywood with exterior glue	0.70
Plastic-coated insulated foam sheathing	0.4 to 1.2
Aluminum foil (.35 mil)	0.05
Vapor barrier paint or primer	0.45
Drywall (unpainted)	5.0
Drywall (painted - latex paint)	2-3

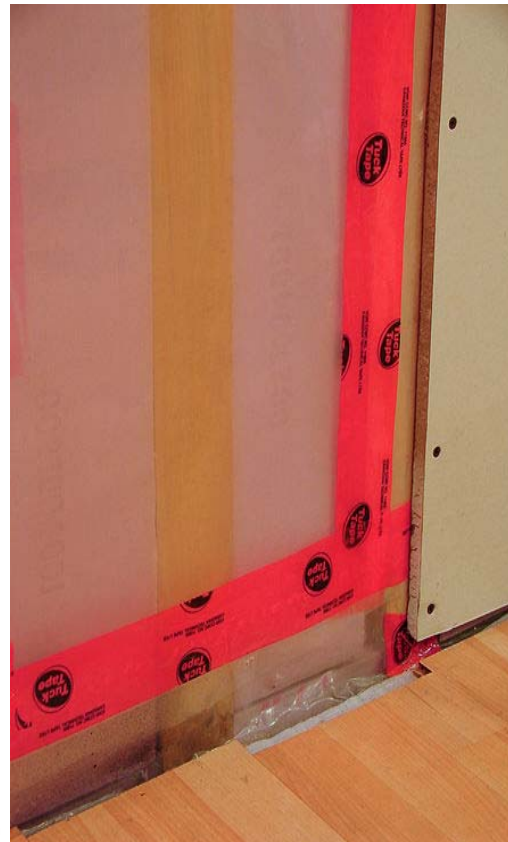

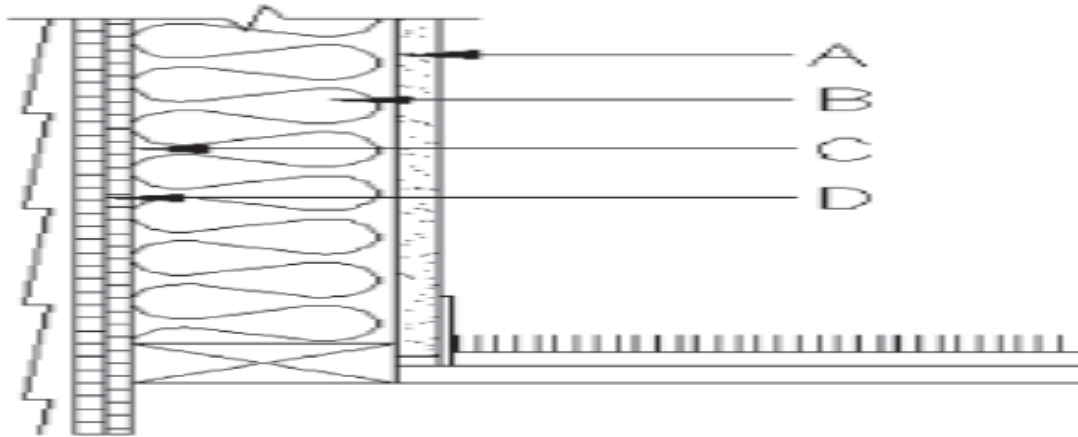

9. In the detail above from an air-conditioned building located in a hot, humid climate, where should the vapor barrier be located?

- At A
- At B
- At C
- At D

## **GYPSUM BOARD CONSTRUCTION**

### **WHAT IS GYPSUM BOARD?**

Gypsum board is the generic name for a family of panel products that consist of a noncombustible core, composed primarily of gypsum, and a paper surfacing on the face, back and long edges. Gypsum board is one of several building materials covered by the umbrella term “gypsum panel products.” All gypsum panel products contain gypsum cores; however, they can be faced with a variety of different materials, including paper and fiberglass mats.

Gypsum board is often called drywall, wallboard, or plasterboard. It differs from other panel-type building products, such as plywood, hardboard, and fiberboard, because of its noncombustible core and paper facers. When joints and fastener heads are covered with a joint compound system, gypsum wall board creates a continuous surface suitable for most types of interior decoration. A typical board application is shown in Figure 1.

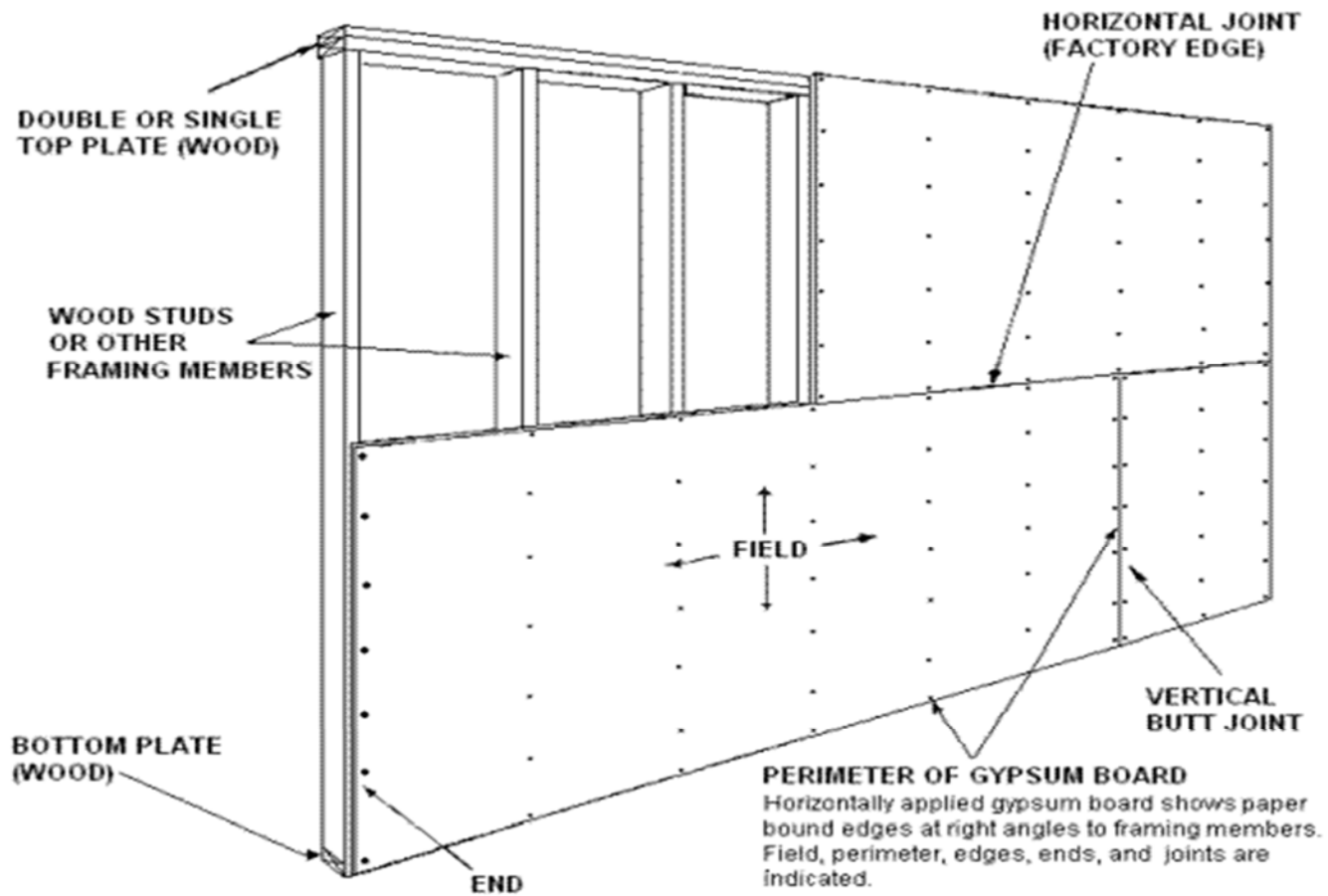

10. The extensive use of gypsum wallboard in residential, commercial, and industrial construction stems from all the following EXCEPT

- o low cost
- o ease of installation
- o **recyclability**
- o fire resistance

## Radon Gas Mitigation Basics (Similar to CH<sub>4</sub>)

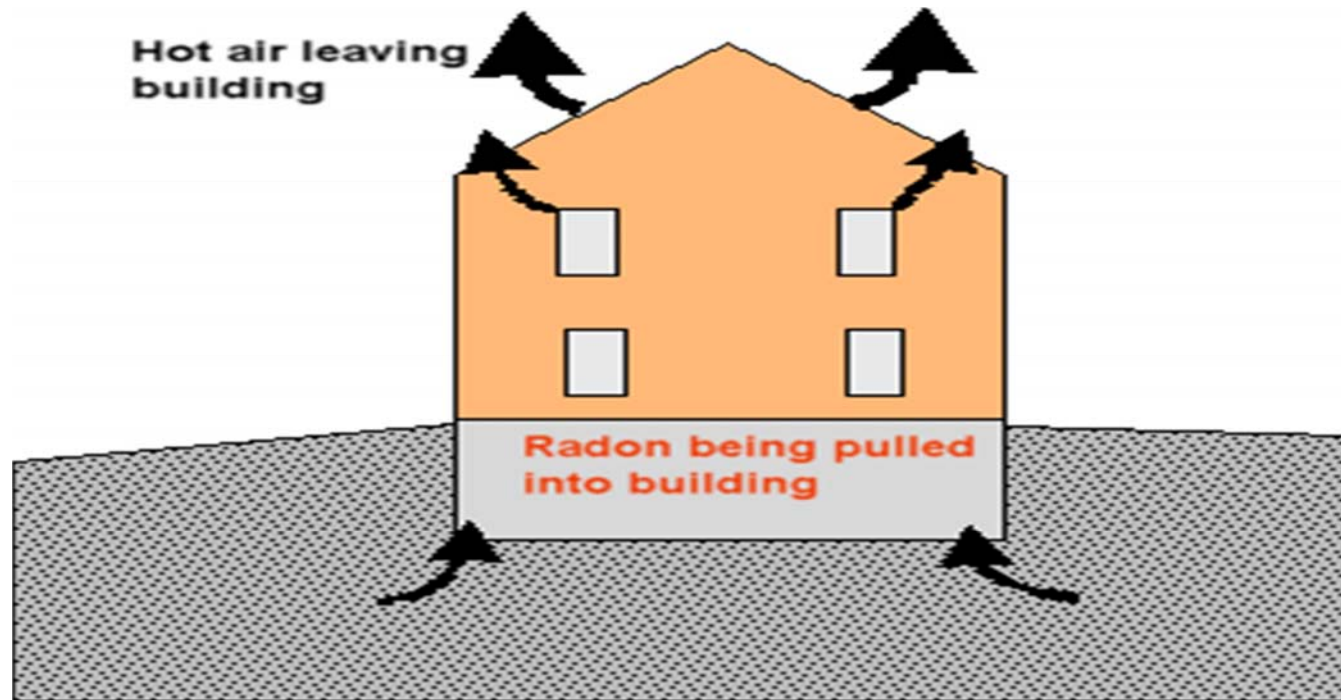



#### **HOW DOES SOIL GAS RADON GET INTO BUILDINGS?**

Soil gas radon enters structures through openings in the foundation. The radon gas concentration in any building is determined by the radon concentration in the soil, soil permeability, and the pressure differential between the soil and the building. Almost all buildings exert a negative pressure (suction) on the soil because of the natural stack effect and exhaust devices that exist in all buildings. The stack effect is the same phenomenon that occurs in a chimney. Hot air rises and leaves the top of the building. The replacement air is pulled in at the bottom of the building. This pull (suction) brings in the soil gas. Of the three factors (concentration, permeability, and pressure) the only one that can be controlled in an existing building is the pressure. If the pressure under the concrete slab can be made to be less than the building's pressure, the soil gas will not enter the building.

## **WHAT IS DONE TO TREAT SOIL GAS RADON?**

Sub-slab depressurization systems create negative pressure under the slab that prevents the soil gas from being drawn into the building. To do this, pipes are inserted through the slab and routed to the exterior of the building. A fan is placed on the pipe and the exhaust is then routed to a safe area above the building. The fan pulls air from under the slab. Removing the air creates a negative pressure (suction) under the slab that is greater than the negative pressure (suction) exerted by the building. This negative pressure (suction) prevents the radon from entering the building.

The treatment for dirt floor basements and crawl spaces is similar to that for areas with slabs. In the case of a crawl space, a fire retardant plastic membrane provides the barrier the slab would normally create. Air is then drawn from under the membrane to create the negative pressure that prevents the entry of the gas.

## **WHY USE A REGISTERED CONTRACTOR?**

All radon systems must meet certain minimum requirements to be safe. A registered mitigation contractor must comply with more than 140 regulations to install a system that meets the requirements set by the EPA. The average consumer should know some of the most basic system requirements to ensure they are getting a safe and reliable system.

## THE FAN CAN NOT BE BELOW THE LIVING SPACE.



Fan mounted on the outside of a house.

The gas that is pulled from under the slab can have very high concentrations of radon gas (several 1000 pCi/L) and any leak on the exhaust side of the fan can cause very high levels of radon to be released. This is why the fan should never be put in the basement. There are three common locations for the fan – outdoors on the side of the building, in a garage or in the attic of the house.

## **THE EXHAUST PIPE OUTPUT MUST BE ABOVE THE ROOF.**

The exhaust output must be in a location that will not allow radon gas to flow back into the structure or a neighboring structure. The exhaust output must be at least 2 feet above or 10 feet away from any potential re-entry point such as a window or bathroom exhaust vent.

## THE SYSTEM MUST HAVE A MONITOR THAT INDICATES THAT THE FAN IS OPERATING.



This is an example of a manometer (vacuum monitor) that indicates whether the fan is working properly.

A manometer, also known as a vacuum monitor, is attached to the exhaust pipe to indicate whether the fan is working to properly pull gases from under the slab or membrane. This simple device is most often installed on the pipe in the basement.

## THE GARAGE WALL PENETRATION SHOULD BE FITTED WITH A UL-LISTED FIRE STOP.



UL listed fire stop assembly in a garage.

The wall between all attached garages and homes is fire rated and its integrity should be maintained by installing a UL-listed fire stop on the pipe where it penetrates the garage wall.

11. A client is proposing to build a residence in an area where there is a high probability of the presence of radon gas. Which of the following is NOT a method that would be selected as a means of radon-resistant construction for the building?

- o Automatic vent damper devices
- o Sub-slab depressurization systems
- o Drain tile loops
- o Soil-gas retarders

Door Hinge



Full Mortise .....



Half Mortise .....

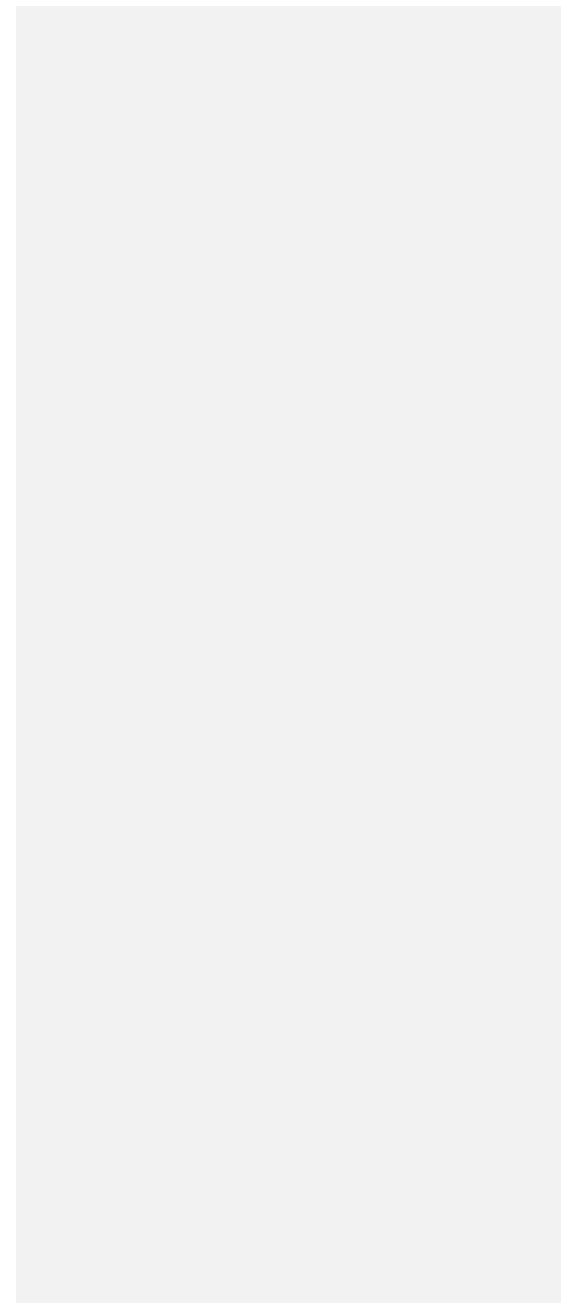





Full Surface

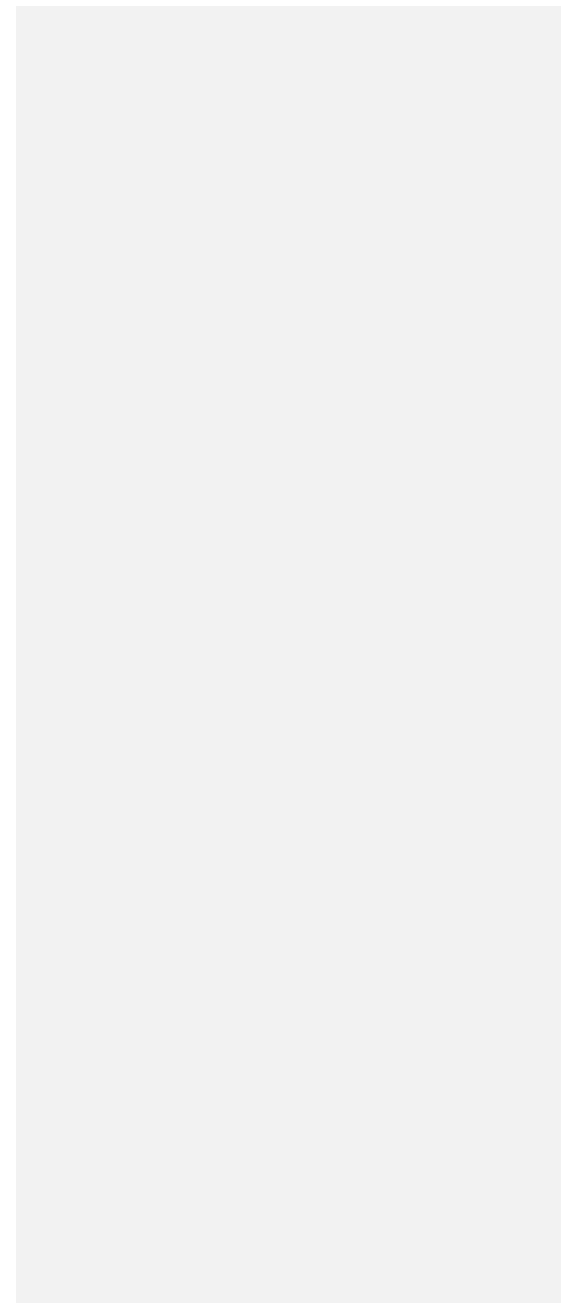

## Determine the type of hinge

There are several pieces of information that are needed to select the proper type of hinge. What is the door material (wood or hollow metal)? What is the frame material (wood or hollow metal, or channel iron)?

How do we determine the proper type of hinge? There are four classifications of hinges:

- Full Mortise - Both leaves are mortised, one leaf to the door and one leaf to the frame. (WD or HM x WF or HFM)
- Half Mortise - One leaf is mortised to the door and the other is surface applied to the frame. (HM x CIF)
- Full Surface - Both leaves are applied to the surface: one to the door and the other to the frame.
- Half Surface - One leaf is mortised to the frame and the other is surface applied to the face of the door. (WD x WF or MCD x HMF)

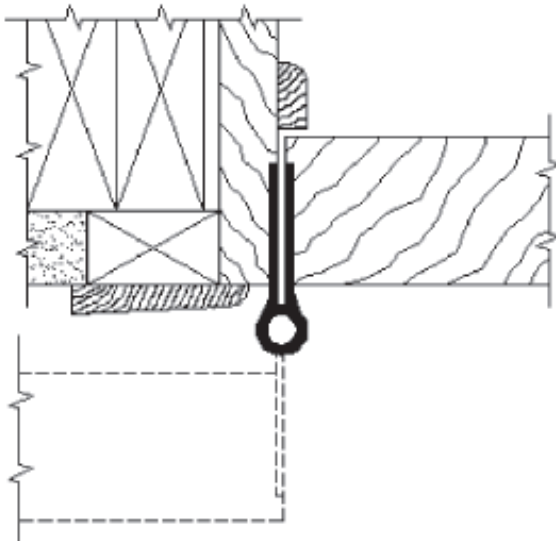

12. The type of door hinge indicated above is a

- full mortise
- full surface
- half mortise
- half surface

### **Portable Fire Extinguisher Types and Use**

If fire extinguishers are available for employee use, it is the employer's responsibility to educate employees on the principles and practices of using a fire extinguisher and the hazards associated with fighting small or developing fires.

To understand how fire extinguishers work, you need to understand a little about fire. Fire is a very rapid chemical reaction between oxygen and a combustible material, which results in the release of heat, light, flames, and smoke.

For fire to exist, the following three elements must be present at the same time:

- **Enough oxygen to sustain combustion,**
- **Enough heat to raise the material to its ignition temperature,**
- **Some sort of fuel or combustible material, and**



This is referred to as the fire triangle. Additionally, there must be a chemical chain reaction between the three elements

Portable fire extinguishers apply an extinguishing agent that will cool burning fuel, displace or remove oxygen, or stop the chemical reaction so a fire cannot continue to burn. When the handle of an extinguisher is compressed, agent is expelled out the nozzle. A fire extinguisher works much like a can of hair spray.



All portable fire extinguishers must be approved by a nationally recognized testing laboratory to verify compliance with applicable standards [29 CFR 1910.157(c)(2)]. Equipment that passes the laboratory's tests are labeled and given an alpha-numeric classification based on the type and size of fire it will extinguish.

Let's take a look at the label pictured. The classification is: 1-

A:10-BC. The letters (A, B, and C) represent the type(s) of fire for which the extinguisher has been approved. The number in front of the A rating indicates how much water the extinguisher is equal to and represents 1.25 gallons of water for every unit of one. For example, a 4-A rated extinguisher would be equal to five (4 x 1.25) gallons of water. The number in front of the B rating represents the area in square feet of a class B fire that a non-expert user should be able to extinguish. Using the above example, a non-expert user should be able to put out a flammable liquid fire that is as large as 10 square feet.



Different types of fire extinguishers are designed to fight different types of fire. The three most common types of fire extinguishers are: air pressurized water, CO2 (carbon dioxide), and dry chemical. The following table provides information regarding the type of fire and which fire extinguisher should be used.

**Extinguisher Type**

**Type of Fire**

Water

**Ordinary Combustibles**

Fires in paper, cloth, wood, rubber, and many plastics require a water type extinguisher labeled A.



CO2 or dry chemical

**Flammable Liquids**

Fires in oils, gasoline, some paints, lacquers, grease, solvents, and other flammable liquids require an extinguisher labeled B.



CO2 or dry chemical

**Electrical Equipment**

Fires in wiring, fuse boxes, energized electrical equipment, computers, and other electrical sources require an extinguisher labeled C.



Multipurpose Dry Chemical

**Ordinary Combustibles, Flammable Liquids, or Electrical Equipment**

Multi-purpose dry chemical is suitable for use on class A, B, and C.

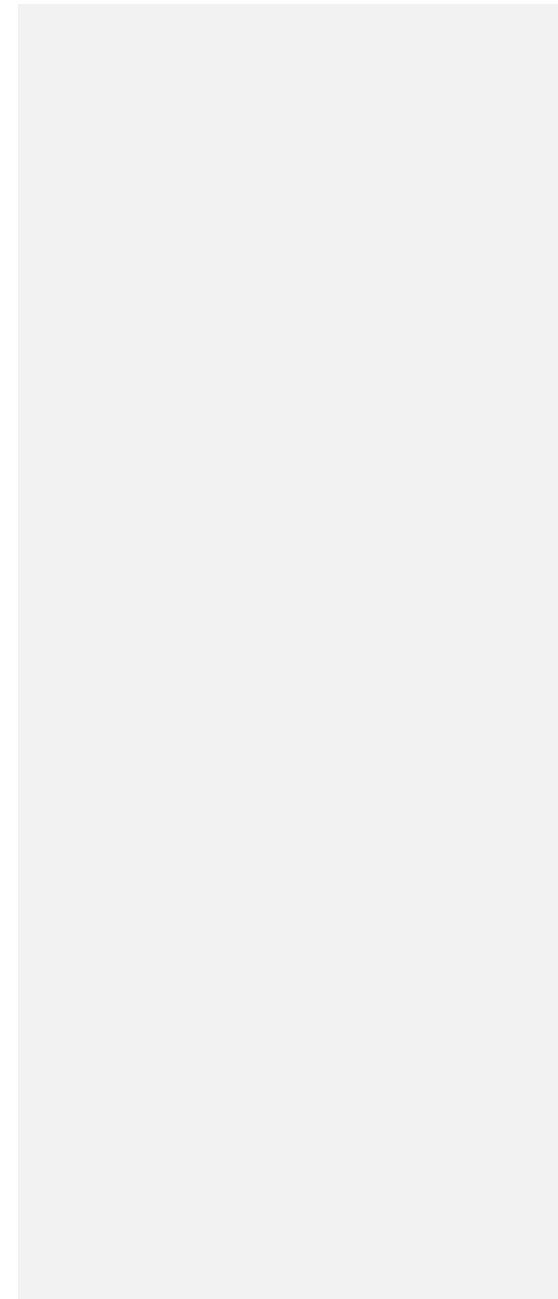

Class D

**Metals**

Fires involving powders, flakes or shavings of combustible metals such as magnesium, titanium, potassium, and sodium require special extinguishers labeled D.

Class K

**Kitchen Fires**

Fires involving combustible cooking liquids such as oils and fats.

**Note:** Your present fire extinguishing equipment may not put out a fire involving vegetable oil in your deep fat fryer.





13. Which of the following types of portable fire extinguisher is appropriate for fires generated by electrical equipment?

- Loaded stream water base only
- Pressure water base only
- Carbon dioxide and dry chemical
- Loaded stream water base, carbon dioxide, and dry chemical

## Defining the Architect's Basic Services Contributed by the AIA Knowledge Resources Staff

### **SUMMARY**

A client's unfamiliarity with the process of architectural design should not hinder that client's comprehension of the phases of design services. This Best Practice introduces first-time clients to the common services of architectural design and the process of design-bid-build.

Note: The deliverables listed below are examples of common architectural deliverables for each phase but are not required of AIA members.

### **SCHEMATIC DESIGN PHASE SERVICES**

During the first phase—schematic design—an architect consults with the owner to determine project goals and requirements. Often this determines the program for the project.

The program, or architectural program, is the term used to define the required functions of the project. It should include estimated square footage of each usage type and any other elements that achieve the project goals.

During schematic design, an architect commonly develops study drawings, documents, or other media that illustrate the concepts of the design and include spatial relationships, scale, and form for the owner to review. Schematic design also is the research phase of the project, when zoning requirements or jurisdictional restrictions are discovered and addressed.

This phase produces a final schematic design, to which the owner agrees after consultation and discussions with the architect. Costs are estimated based on overall project volume. The design then moves forward to the design development phase.

***Deliverables: Schematic design often produces a site plan, floor plan(s), sections, an elevation, and other illustrative materials; computer images, renderings, or models. Typically the drawings include overall***

*dimensions, and a construction cost is estimated. Note: The contract may actually spell out what is to be delivered.*

### **DESIGN DEVELOPMENT PHASE SERVICES**

Design development (DD) services use the initial design documents from the schematic phase and take them one step further. This phase lays out mechanical, electrical, plumbing, structural, and architectural details.

Typically referred to as DD, this phase results in drawings that often specify design elements such as material types and location of windows and doors. The level of detail provided in the DD phase is determined by the owner's request and the project requirements. The DD phase often ends with a formal presentation to, and approval by, the owner.

*Deliverables: Design development often produces floor plans, sections, and elevations with full dimensions. These drawings typically include door and window details and outline material specifications.*

### **CONSTRUCTION DOCUMENT PHASE SERVICES**

The next phase is construction documents (CDs).

Once the owner and architect are satisfied with the documents produced during DD, the architect moves forward and produces drawings with greater detail. These drawings typically include specifications for construction details and materials.

Once CDs are satisfactorily produced, the architect sends them to contractors for pricing or bidding, if part of the contract. The level of detail in CDs may vary depending on the owner's preference. If the CD set is not 100-percent complete, this is noted on the CD set when it is sent out for bid. This phase results in the contractors' final estimate of project costs. To learn more about the most common ways owners select a contractor, see Best Practice 05.03.01, "Qualifications-Based vs. Low-Bid Contractor Selection."

*Deliverables: The construction document phase produces a set of drawings that include all pertinent information required for the contractor to price and build the project.*

### **BID OR NEGOTIATION PHASE SERVICES**

The first step of this phase is preparation of the bid documents to go out to potential contractors for pricing. The bid document set often includes an advertisement for bids, instructions to bidders, the bid form, bid documents, the owner-contractor agreement, labor and material payment bond, and any other sections necessary for successful price bids. For some projects that have unique aspects or complex requirements, the architect and owner elect to have a pre-bid meeting for potential contractors.

After bid sets are distributed, both the owner and architect wait for bids to come in. The owner, with the help of the architect, evaluate the bids and select a winning bid. Any negotiation with the bidder of price or project scope, if necessary, should be done before the contract for construction is signed. The final step is to award the contract to the selected bidder with a formal letter of intent to allow construction to begin.

***Deliverables: The final deliverable is a construction contract. Once this document is signed, project construction can begin.***

### **CONSTRUCTION PHASE SERVICES**

Contract administration (CA) services are rendered at the owner's discretion and are outlined in the owner-architect construction agreement. Different owner-architect-contractor agreements require different levels of services on the architect's part. CA services begin with the initial contract for construction and terminate when the final certificate of payment is issued.

The architect's core responsibility during this phase is to help the contractor to build the project as specified in the CDs as approved by the owner.

Questions may arise on site that require the architect to develop architectural sketches: drawings issued after construction documents have been released that offer additional clarification to finish the project properly. Different situations may require the architect to issue a Change in Services to complete the project.

***Deliverables: A successfully built and contracted project.***

### **RESOURCES**

[Absoluteco.com](http://Absoluteco.com)

[Greenerade.com](http://Greenerade.com)

[Saum Greenerade @facebook](#)

[Endlesschool.com](http://Endlesschool.com)

#### More Best Practices

The following AIA Best Practices provide additional information related to this topic:

17.02.05 Qualifications-Based vs. Low-Bid Contractor Selection

12.03.02 How Roles Change in Design-Build

11.02.04 Terminology: As-Built Drawings, Record Drawings, Measured Drawings The Knowledge Resources Staff based this Best Practice on definitions in the AIA Contract Documents as well as in the 12th, 13th, and the forthcoming 14th editions of The Architect's Handbook of Professional Practice.

## Sequence of Productions: Foundation is always first.

14. In a fast-track, single-story industrial project, which of the following schematic design and design development considerations is most likely to have a significant effect on the successful sequencing of the construction?

- o **Foundation design**
- o HVAC systems design
- o Roofing materials selection
- o Window design

## Motion of a Mass on a Spring

The mass on a spring motion was discussed in more detail as we sought to understand the mathematical properties of objects that are in periodic motion. Now we will investigate the motion of a mass on a spring in even greater detail as we focus on how a variety of quantities change over the course of time. Such quantities will include forces, position, velocity and energy - both kinetic and potential energy.

### Hooke's Law

Investigation of the forces exerted by a spring on a hanging mass: Consider the system shown at the right with a spring attached to a support. The spring hangs in a relaxed, unstretched position. If you were to hold the bottom of the spring and pull downward, the spring would stretch. If you were to pull with just a little force, the spring would stretch just a little bit. And if you were to pull with a much greater force, the spring would stretch a much greater extent. Exactly what is the quantitative relationship between the amount of pulling force and the amount of stretch?

To determine this quantitative relationship between the amount of force and the amount of stretch, objects of known mass could be attached to the spring. For each object which is added, the amount of stretch could be measured. The force which is applied in each instance would be the weight of the object. A regression analysis of the force-stretch data could be performed in order to determine the quantitative relationship between the force and the amount of stretch.

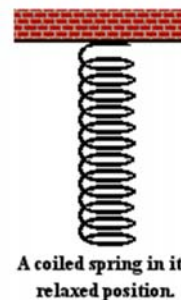

$$\text{Hooke's law } F = kx, \text{ where } k = mg/L. \quad T = 2\pi\sqrt{\frac{m}{k}} = 2\pi\sqrt{\frac{m}{mg/L}}$$

15. Which of the following basic structural systems **would be appropriate** for a high-tech building with equipment and functions that are extremely sensitive to vibrations?

**o Poured-in-place concrete beam-and-slab system**

o Heavy steel frame with composite floor slab with rubber insulators

o Heavy (12) gauge metal studs with a long-span steel joist with a 5-inch-thick concrete slab

o Masonry bearing walls with wood joists and wood deck with a 4-inch-thick gypsum concrete topping slab



## Improving Indoor Air Quality

### Basic Information on Pollutants and Sources of Indoor Air Pollution

- [Asbestos](#)
- [Biological Pollutants](#)
- [Carbon Monoxide \(CO\)](#)
- [Formaldehyde/Pressed Wood Products](#)
- [Lead \(Pb\)](#)
- [Nitrogen Dioxide \(NO<sub>2</sub>\)](#)
- [Pesticides](#)
- [Radon \(Rn\)](#)
- [Respirable Particles](#)
- [Secondhand Smoke/ Environmental Tobacco Smoke](#)
- [Stoves, Heaters, Fireplaces, and Chimneys](#)
- [Volatile Organic Compounds \(VOCs\)](#)

The information provided here is based on current scientific and technical understanding of the issues presented and is reflective of the jurisdictional boundaries established by the statutes governing the co-authoring agencies. Following the advice given will not necessarily provide complete protection in all situations or against all health hazards that may be caused by indoor air pollution.

- [Basic Information About Indoor Air Quality](#)
- **There are three basic strategies to improve indoor air quality**
- [Measuring Pollutant Levels and Weatherizing Your Home](#)
- [What if You Live in an Apartment?](#)
- [Do You Suspect Your Office Has an Indoor Air Problem?](#)
- ["The Inside Story: A Guide to Indoor Air Quality"](#)

**There are three basic strategies to improve indoor air quality**

1. Source Control
2. Improved Ventilation, and
3. Air cleaners

## Source Control

**Usually the most effective way to improve indoor air quality is to eliminate individual sources of pollution or to reduce their emissions.** Some sources, like those that contain asbestos, can be sealed or enclosed; others, like gas stoves, can be adjusted to decrease the amount of emissions. In many cases, source control is also a more cost-efficient approach to protecting indoor air quality than increasing ventilation because increasing ventilation can increase energy costs.

## Ventilation Improvements

*For most indoor air quality problems in the home, source control is the most effective solution.*

**Another approach to lowering the concentrations of indoor air pollutants in your home is to increase the amount of outdoor air coming indoors.** Most home heating and cooling systems, including forced air heating systems, do not mechanically bring fresh air into the house. Opening windows and doors, operating window or attic fans, when the weather permits, or running a window air conditioner with the vent control open increases the outdoor ventilation rate. Local bathroom or kitchen fans that exhaust outdoors remove contaminants directly from the room where the fan is located and also increase the outdoor air ventilation rate.

It is particularly important to take as many of these steps as possible while you are involved in short-term activities that can generate high levels of pollutants — for example, painting, paint stripping, heating with kerosene heaters, cooking, or engaging in maintenance and hobby activities such as welding, soldering, or sanding. You might also choose to do some of these activities outdoors, if you can and if weather permits.

Advanced designs of new homes are starting to feature mechanical systems that bring outdoor air into the home. Some of these designs include energy-efficient heat recovery ventilators (also known as air-to-air heat exchangers). For more information about whole house ventilation system options, see the U.S. Dept. of Energy's [Energy Saver: Whole-House Ventilation](#).

## Air Cleaners

There are many types and sizes of [air cleaners](#) on the market, ranging from relatively inexpensive table-top models to sophisticated and expensive whole-house systems. Some air cleaners are highly effective at particle removal, while others, including most table-top models, are much less so. Air cleaners are generally not designed to remove gaseous pollutants.

**The effectiveness of an air cleaner depends on how well it collects pollutants from indoor air (expressed as a percentage efficiency rate) and how much air it draws through the cleaning or filtering element (expressed in cubic feet per minute).** A very efficient collector with a low air-circulation rate will not be effective, nor will a cleaner with a high air-circulation rate but a less efficient collector. The long-term performance of any air cleaner depends on maintaining it according to the manufacturer's directions.

Another important factor in determining the effectiveness of an air cleaner is the strength of the pollutant source. Table-top air cleaners, in particular, may not remove satisfactory amounts of pollutants from strong nearby sources. People with a sensitivity to particular sources may find that air cleaners are helpful only in conjunction with concerted efforts to remove the source.

Over the past few years, there has been some publicity suggesting that houseplants have been shown to reduce levels of some chemicals in laboratory experiments. There is currently no evidence, however, that a reasonable number of houseplants remove significant quantities of pollutants in homes and offices. Indoor houseplants should not be over-watered because overly damp soil may promote the growth of microorganisms which can affect allergic individuals.

At present, EPA does not recommend using air cleaners to reduce levels of radon and its decay products. The effectiveness of these devices is uncertain because they only partially remove the radon decay products and do not diminish the amount of radon entering the home. EPA plans to do additional research on whether air cleaners are, or could become, a reliable means of reducing the health risk from radon.

16. Which of the following is the most effective method to control indoor air quality?

Exhaust air

Source reduction

Air cleaning and filtration

Increased temperature and lowered humidity

17. Which of the following diagrams would best indicate an exterior **self-supporting** non-load-bearing wall design?

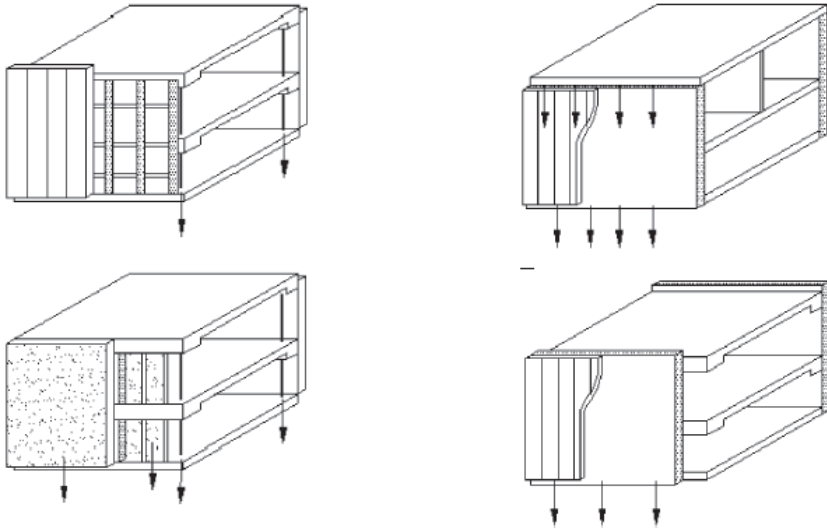

Arrows give the information

## Elevator Selection Process

### Step 1: Travel Height

- Selecting the optimal elevator type for your project depends upon the elevator travel distance
- The chart below identifies elevators most commonly selected for specific travel heights

### Step 2: Elevator Quantity and Size

- These are determined by floor population, building use or building type and national and local codes.

### Step 3: Hoistway Requirements

- To accommodate heavier reinforcements to rails in seismic zones 2 or greater, additional hoistway space is required

### Step 4: Machine/Control Room Requirements

#### Hydraulic Systems

- Separate machine room required at bottom landing
- Machine room can be located remotely or adjacent to hoist way at bottom landing

#### Machine-Roomless System

- Requires separate control space/room
- Flexible control space/room placement—up to 250 feet away from top of hoistway

### Step 5: Car Design and Finishes

- Flexibility in designing and selecting car walls, ceilings, lighting, handrails, bumper rails and fixtures



*Absoluteco.com*

*Greenerade.com*

*Saum Greenerade @facebook*

*Endlesschool.com*

18. Which of the following is NOT significant in selecting the type of elevator to be used?

Power used to operate the elevator

Height of the building

Speed of the elevator

Number of building occupants

## **CRIME PREVENTION THROUGH ENVIRONMENTAL DESIGN (CPTED)**

### Four Principles of CPTED

- Natural Surveillance
- Natural Access Control
- Territorial Reinforcement
- Maintenance and Management

### “Three D” Approach

- Designation
- Definition
- Design
- 

### BASIC DESIGN AND MANAGEMENT STRATEGIES

- Sight Lines
- Lighting
- Concealed or Isolated Routes
- Entrapment Areas
- Isolation
- Land Use Mix
- Activity Generators
- Ownership, Maintenance and Management
- Signs and Information
- Overall Design
-

19. When designing a residential development, which of the following is an example of the “Crime Prevention through Environmental Design” strategy of encouraging natural surveillance?

- Reducing the overall amount of site lighting
- Visually screening parking areas with tall landscaping
- Placing the majority of windows to the rear of residences
- Providing a primary living space with a view of the street

#### **WATERBORNE PRESERVATIVES**

Inorganic waterborne preservatives are the most popular and commonly available types of preservatives used for treating wood. They include alkaline copper quaternary (ACQ), both copper boron azole type A (CBA-A) and copper azole type B (CA-B), chromated copper arsenate (CCA), ammoniacal copper zinc arsenate (ACZA), and inorganic boron (SBX). All of these preservatives are dissolved in water, so after the wood is permitted to dry, the surface readily accepts paints and stains.

ACQ (types A, B, C, and D) are composed of copper and a quaternary ammonium compound dissolved in an aqueous solution of ammonia and/or ethanolamine.

Inorganic Waterborne preservatives are the most popular treatment for wood commercially available. ACQ or Alkaline Copper Quaternary is one of those. The small trace amounts of copper will dissolve the aluminum away. Info in Architectural Graphic Standards in the wood preservation area. Although galvanized and stainless steel would react with it, just not nearly as harmfully as aluminum.

For NCARB's purposes, Gold is basically impervious to galvanic action, and everything destroys aluminum, think of it that way. I think you might have the chart reversed in your head? Stainless is somewhere in the middle, and more or less invulnerable compared to aluminum.

20. All of the following types of fasteners are recommended for use with wood treated with inorganic waterborne preservatives EXCEPT

- aluminum
- stainless steel
- hot-dipped galvanized
- hot-tumbled galvanized

[Absoluteco.com](http://Absoluteco.com)

[Greenerade.com](http://Greenerade.com)

[Saum Greenerade @facebook](#)

[Endlesschool.com](http://Endlesschool.com)

Steel: Lower depth, led deflection  
Wood: Inexpensive  
Combination: Stiffer/Lighter

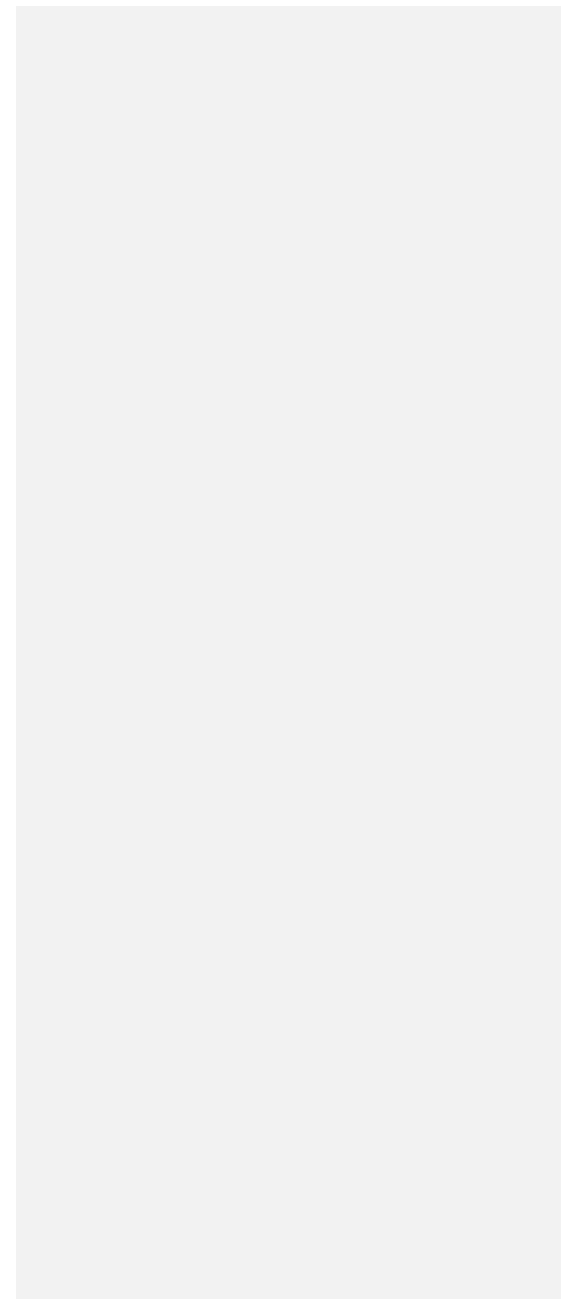

21. When compared to a steel beam-and-bar joist floor system, the use of composite construction will likely result in which of the following? Check the two that apply.

- A. Stiffer floor
- B. Heavier frame
- C. Lighter frame
- D. More expensive system
- E. Increased fabrication time
- F. Faster erection time

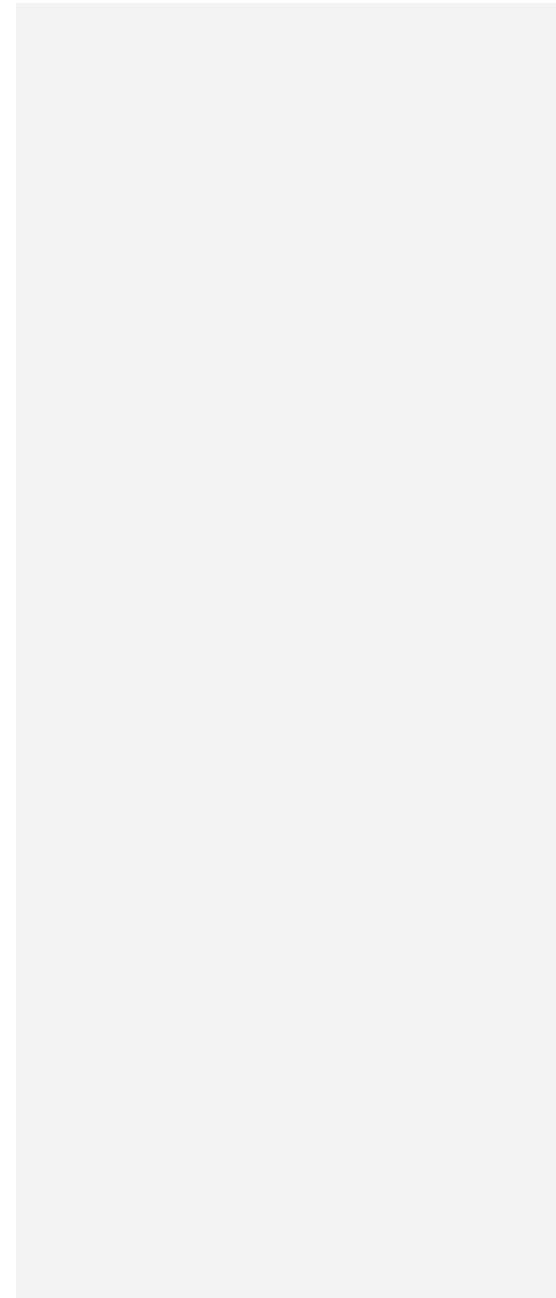
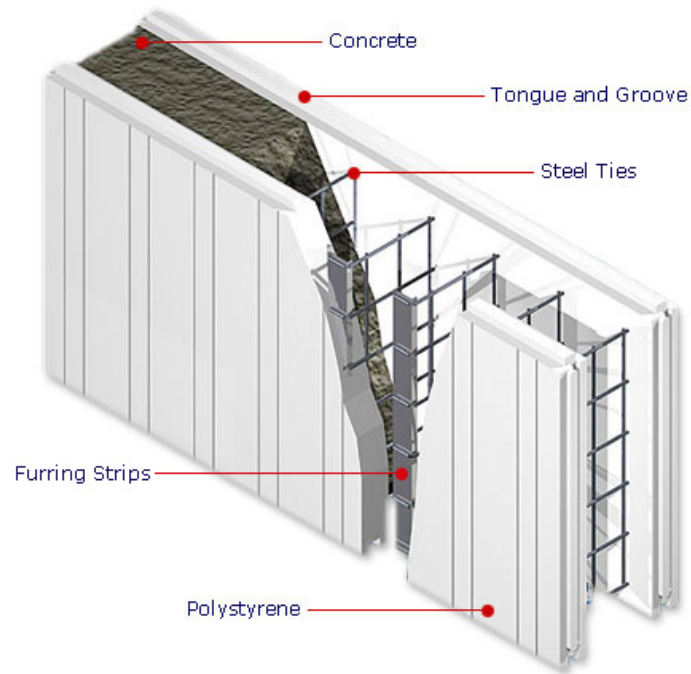



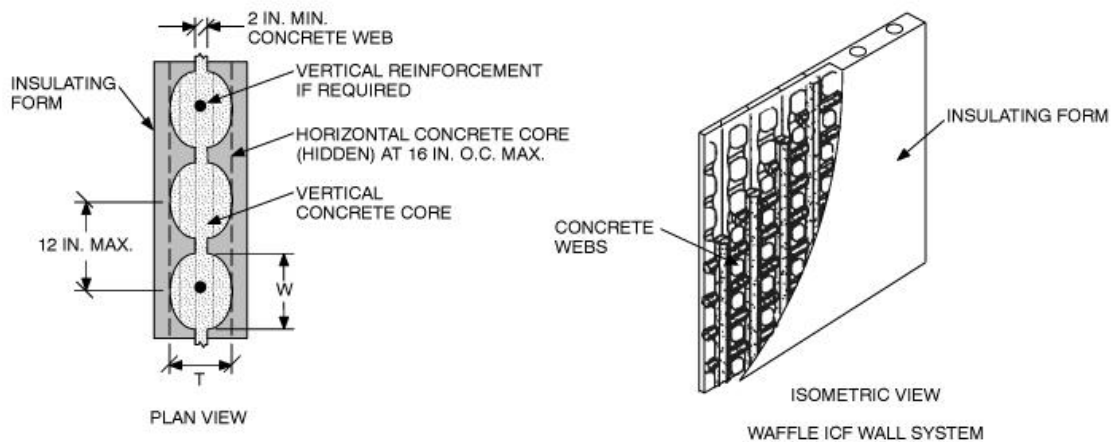

[Absoluteco.com](http://Absoluteco.com)

[Greenerade.com](http://Greenerade.com)

[@facebook](https://www.facebook.com/SaumGreenerade)

[Endlesschool.com](http://Endlesschool.com)

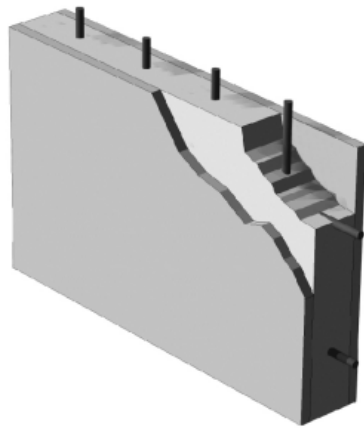

Flat wall core with  
foam in place

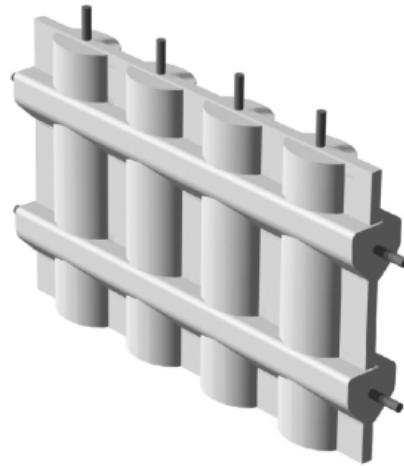

Waffle grid core with  
foam removed for clarity

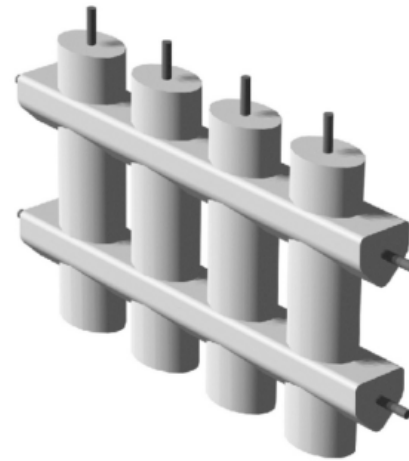

Screen grid core with  
foam removed for clarity

Courtesy of the Portland Cement Association, 2001

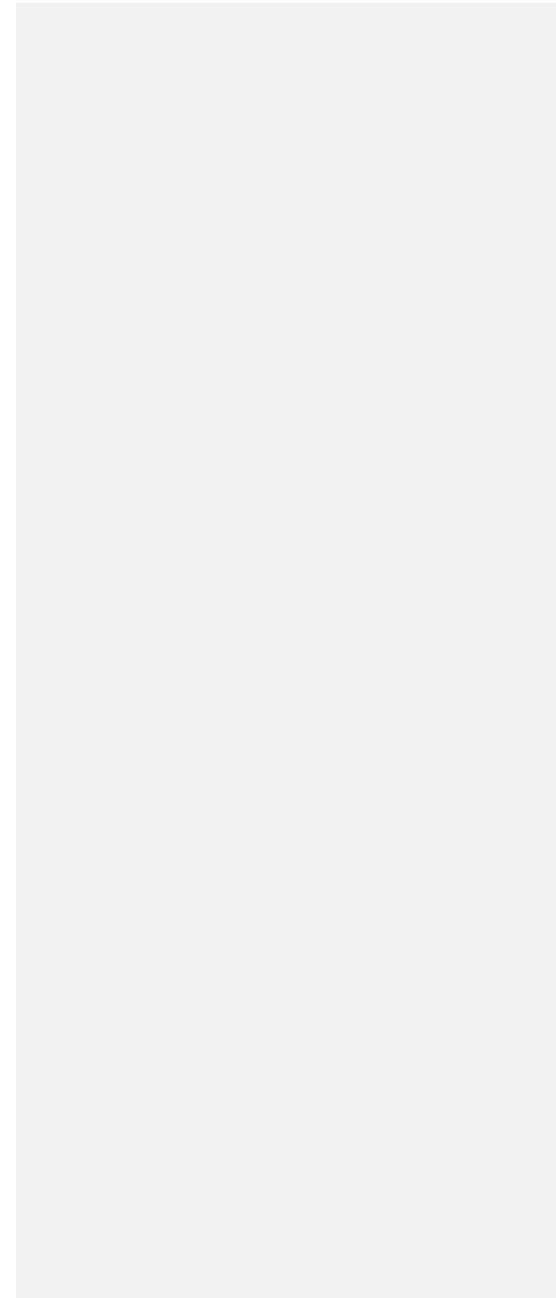

22. The figure shown above represents which of the following types of insulating concrete form (ICF) system?

- Waffle-grid
- Waffle-core
- Waffle-cast
- Waffle-slab

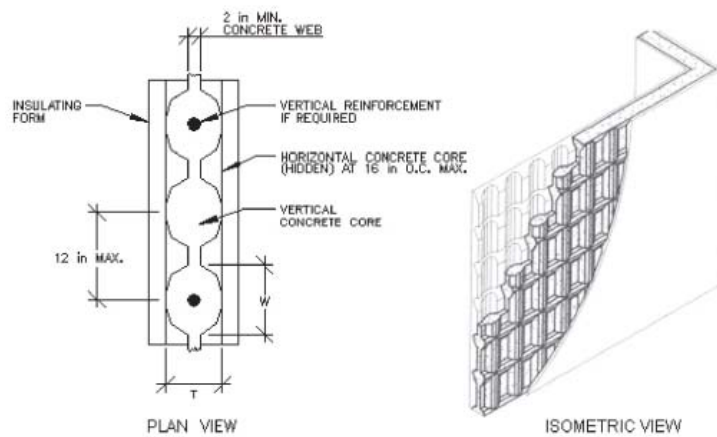

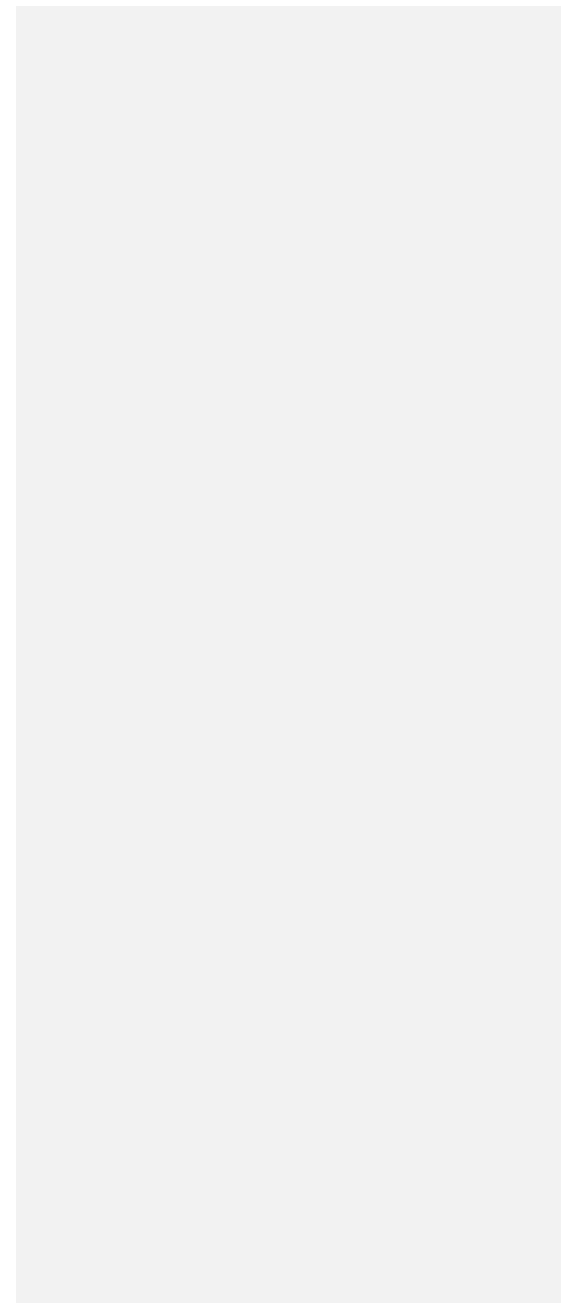
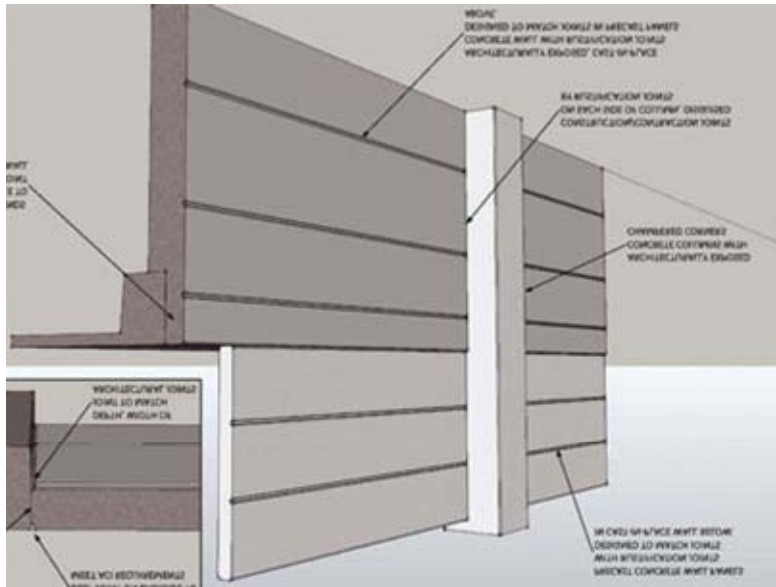

23. Which of the following actions can achieve the most significant cost reduction in value engineering a precast concrete warehouse?

- Removing reveals in the panels
- Changing the exposed aggregate in the concrete
- Maximizing and standardizing the panel sizes
- Removing the integral color from the concrete mix

### **Waterproofing Vs. Damp-proofing – Which Is The Best Way?**

Your home's moisture level is a serious matter. Too much moisture and your house becomes a breeding ground for mold and even worse things. And of course, nobody wants a leaky basement that floods all the time.

One really important matter to consider is whether your house has damp-proofing or waterproofing. They both sound like the same thing, but there are major differences. The experts will tell you that waterproofing is better, hands down, and that damp-proofing is really not waterproofing at all. But why is this so, especially considering that damp-proofing is the cheaper alternative? First, let's take a look at what these two words mean.

Damp-proofing uses a mixture that is mostly tar based. It covers the foundation and protects it from moisture. Waterproofing uses a material that contains rubber and is capable of stretching to cover cracks as your house settles. The goal of both methods is the same – to keep out unwanted moisture. But, if we consider the differences, you'll see why waterproofing is the preferred method.

24. A waterproofing treatment should be specified in lieu of a damp proofing treatment for subsurface masonry when which of the following conditions is present?

- Hydrostatic pressure
- A low frost line
- Sandy subsurface soils
- Expansive subsurface soils

*Absoluteco.com*

*Greenerade.com*

*Saum Greenerade @facebook*

*Endlesschool.com*

25. The passage of water under pressure through concrete cracks is defined as
- capillary action
  - seepage
  - saturation
  - leakage



26. An elevator hoistway would be constructed to which of the following model code standards for walls?

- Shaft enclosure
- Occupancy separation
- Area separation
- Demising

27. Which of the following is true of humidity?

- Human thermal comfort is unaffected by relative humidity.
- Cold air is able to hold more moisture vapor than warm air.
- Dewpoint is unreachable in the middle of a homogeneous material.
- Condensation in a building can contribute to mold growth.

28. The two-inch gap at the perimeter of the wood athletic floor shown above is provided to
- o allow for proper alignment of the flooring system
  - o allow air circulation
  - o accommodate expansion and contraction
  - o increase resiliency of the floor

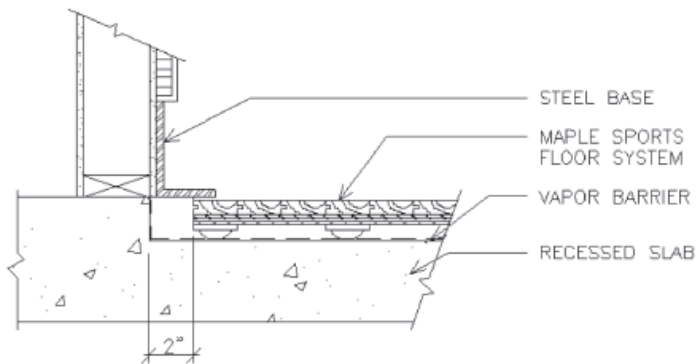

29. Which of the following is the most appropriate flashing detail for the design of brick veneer (cavity) wall construction?  
D

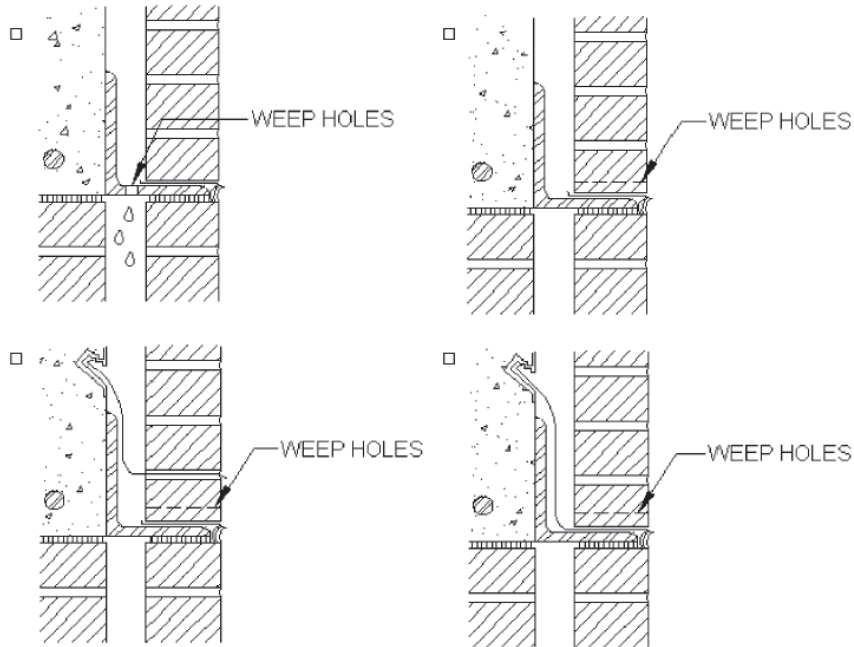

30. Which jamb anchor should be used for installation in a masonry wall?

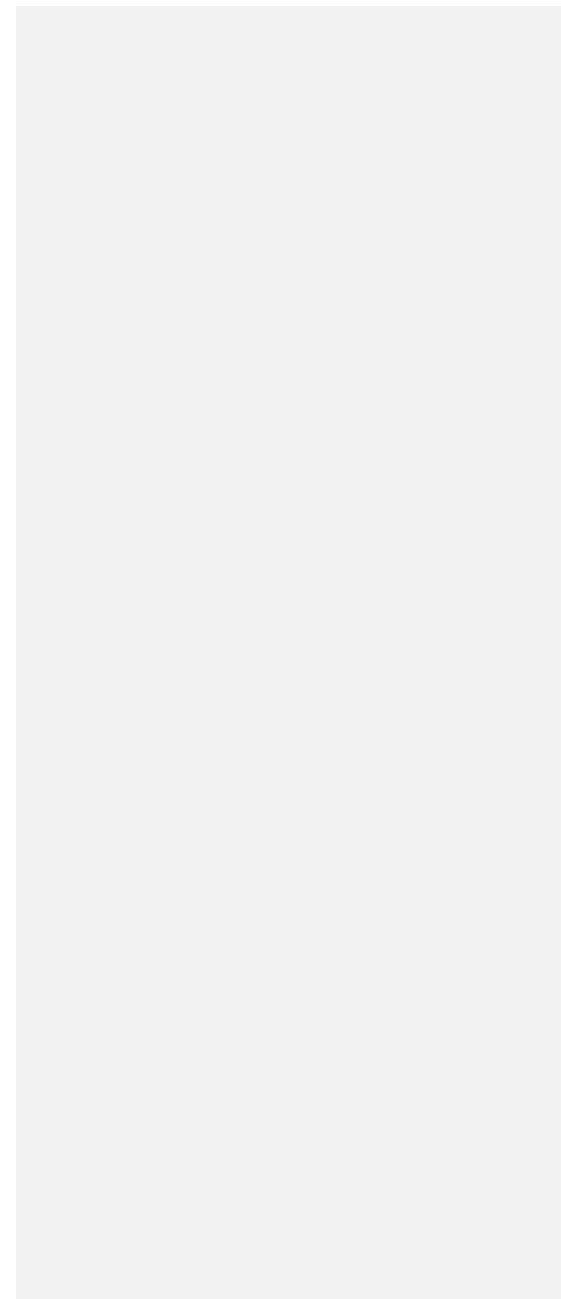
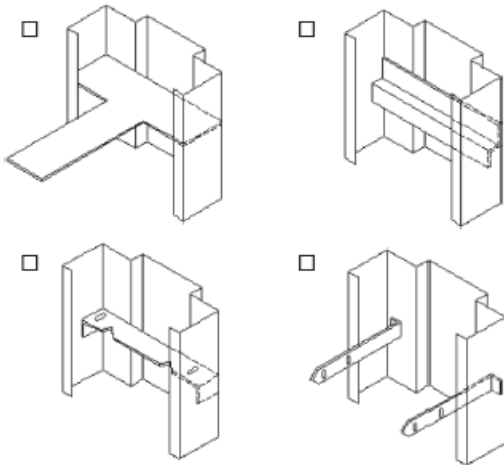

## Parging Plaster: Scratch, Brown Finish

Parging is a construction technique used to finish the surface of a [masonry](#) wall. It is similar to [stucco](#), but uses a masonry-based [mortar](#) rather than a traditional stucco mixture. This material can be installed over new or existing walls, and it is used in both residential and commercial applications. The term is used both as a verb and a noun to describe the application process as well as the mixture itself.

Most parging mixtures are made from a blend of lime, [Portland cement](#), water, and [masonry cement](#). While it is possible for users to create their own blends, it is typically easier to buy a pre-made parging mix from a hardware or home improvement store when attempting this project. Water should be carefully added according to the directions on the package. A mix that is too wet may crack, while overly dry mixtures may not stick to the wall.

This material is applied using a standard masonry trowel, and it is generally installed in very thin coats. The walls should be wet first, which helps the mixture adhere to the masonry. Depending on the desired finish, the walls may be heavily textured or very smooth. To keep parged walls smooth, the person applying it should keep his trowel very wet during the application. Most installers will apply a second coat of material after the first layer has been given time to dry.

This material can be used on both interior and exterior walls. It may be used on vertical surfaces, foundations, columns, or any other surface made of concrete, brick, or stone. Because the ingredients in most parging mixtures are relatively heavy, it is important for installers to use only very thin layers of material. Multiple coats can be used to create a thicker finish as needed.

### Suggest Edits

Parging is an economical and easy-to-apply solution for covering unattractive masonry surfaces. It can cover cracks and water damage, or even holes and voids. The mortar may also help to seal small air leaks in a concrete wall, which may lead to a slight improvement in energy efficiency. Parged walls can even be painted to complement the surrounding surfaces.

While this material offers a number of benefits, it is also associated with several drawbacks that should be considered. In some cases, it may cover signs of serious structural damage, and an unscrupulous seller may use this material to cover signs of damage before putting a house on the market. Fortunately, most home inspectors will be able to spot this type of issue so that potential buyers can understand the true condition of the res

*Absoluteco.com*

*Greenerade.com*

*Saum Greenerade @facebook*

*Endlesschool.com*

31. The terms “scratch coat,” “brown coat,” and “finish coat” refer to
- painting
  - parging
  - paving
  - plastering

[Absoluteco.com](http://Absoluteco.com)

[Greenerade.com](http://Greenerade.com)

[Saum Greenerade @facebook](#)

[Endlesschool.com](http://Endlesschool.com)

32. Which of the following types of concrete construction is reinforced with tensioned high-strength steel-wire strands?

- Tilt-up
- Prestressed
- Cast-in-place
- Precast



*Absoluteco.com*

*Greenerade.com*

*Saum Greenerade @facebook*

*Endlesschool.com*

33. Locating footings at or below the frost line is important because doing so
- o promotes good drainage
  - o makes perimeter insulation unnecessary
  - o **helps to stabilize the foundation system**
  - o simplifies excavation during winter construction

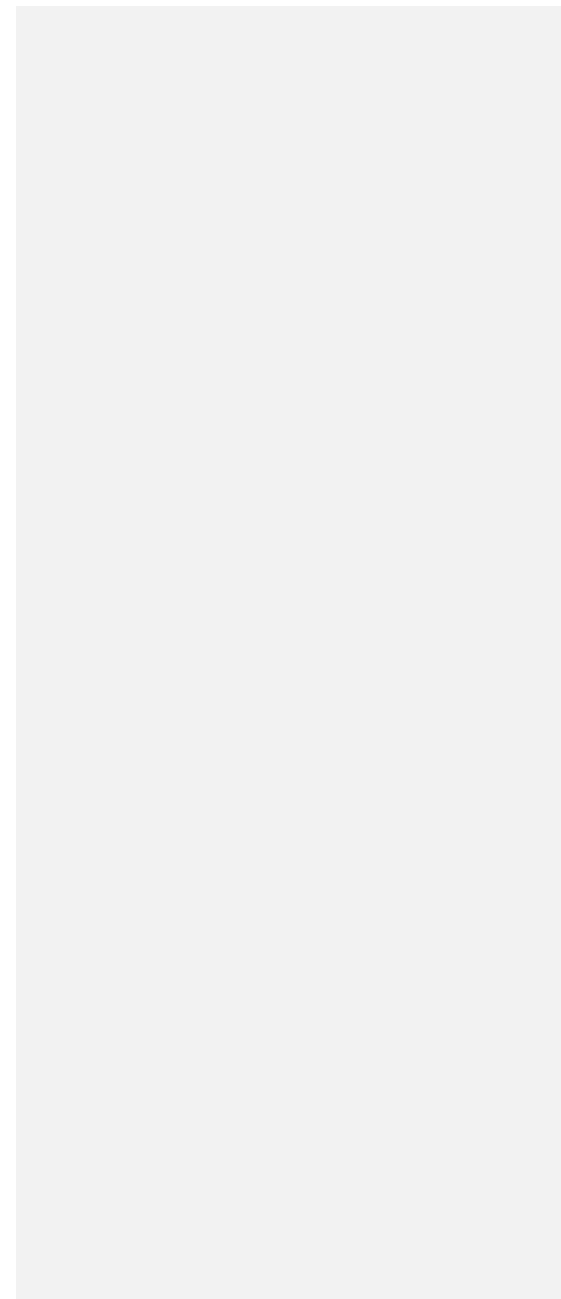
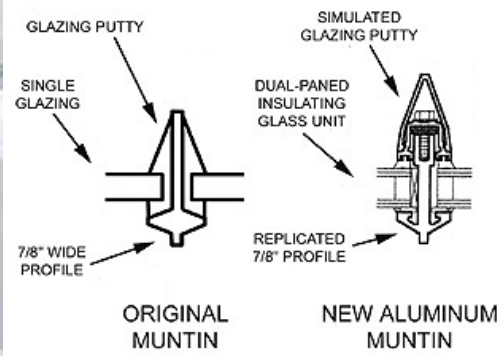

34. Which letter in the figure above indicates a muntin?

- A
- B
- C
- D

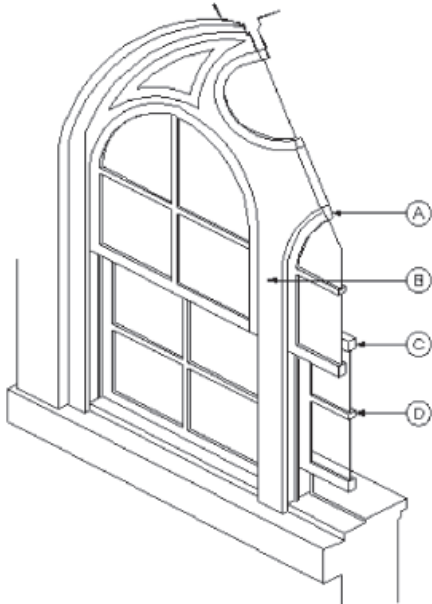

35. Which of the following brick veneer patterns is the most expensive per square foot? D

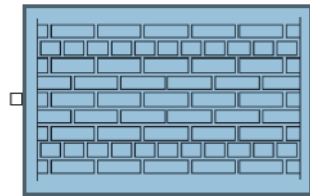
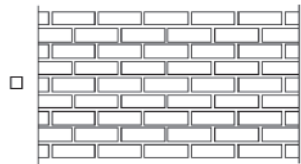

Workmanship: Patterns: Odd, small bricks, and so on

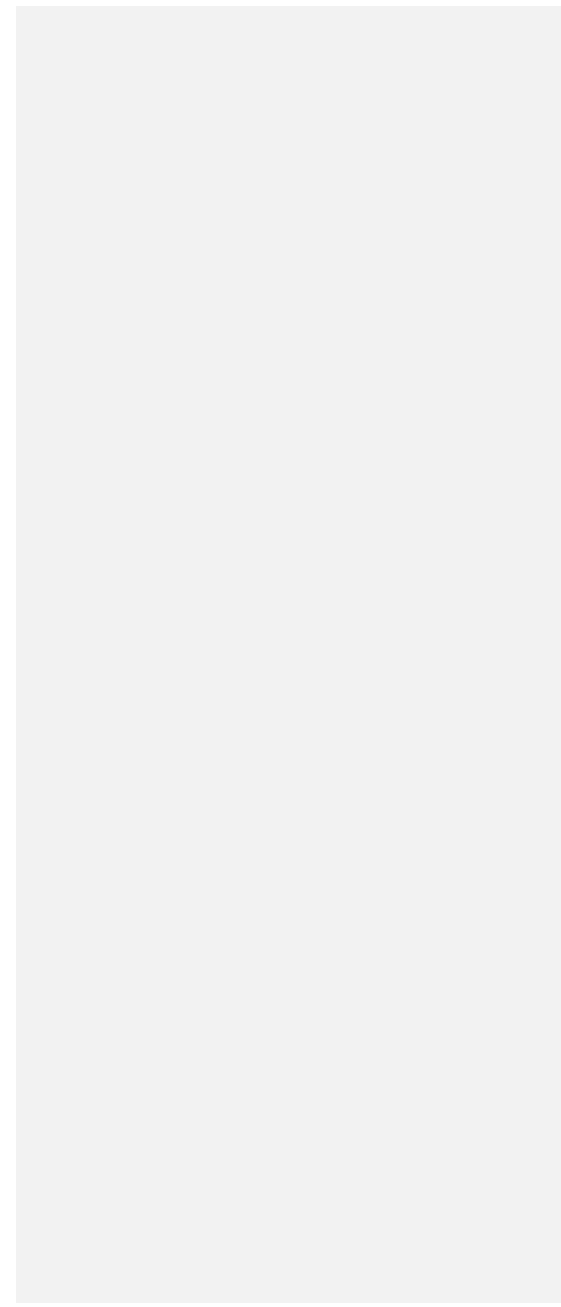
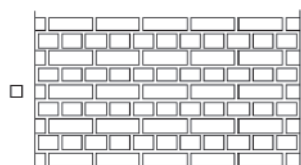
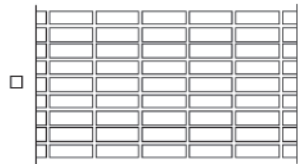

## Types Of Locks

When looking at purchasing locks for your home or business, the amount of options can certainly be overwhelming. There are many different types of locks and several different security factors to consider before purchasing. This page will explain the different types of locks and the security features that should be considered.

Although there are many types of locks, the four most common are padlocks, deadbolts, knob locks, and levers.



### Padlocks

Padlocks are the only type of lock that is typically not permanently attached to anything else. Padlocks come in a range of sizes, are free standing and portable, and are one of the most easily recognizable types of lock. Padlocks come in two main varieties: combination and keyed. Combination locks have one or more number dials that open the lock when the correct combination is entered. They are often easy to decode or shim open. Keyed padlocks have several options to consider. There are rekeyable and non-rekeyable padlocks. If a padlock is non-rekeyable, then you cannot change the key that opens the lock (for example to make it use the same key as your house). Padlocks can be key-retaining or non-key-retaining. A key-retaining padlock does not allow the key to be removed while the padlock is open. Finally, padlocks can have a shrouded shackle. This is an extension of the body where the shoulders of the padlock raise up the sides of the shackle to make it far harder for bolt cutters to cut the padlock.



### Deadbolts

Deadbolts are generally installed on external doors and have a few more options to consider than padlocks. Deadbolts come in three primary varieties: single, double, and lockable thumbturn. Single cylinder deadbolts are found on most American homes. They use a key cylinder on the outside and a thumbturn (rosary) on the inside to open or close the lock. These deadbolts have one primary weakness. If access to the inside is possible (via a nearby window or even through the peephole using simple tools), the door can be opened using the thumbturn. A double cylinder

deadbolt uses a key cylinder on the inside and the outside of the door to solve this issue. These have the clear disadvantage of always requiring a key to open the door from the inside if it is locked. This can pose a significant problem in a fire or other emergency situation. If used in a residential situation, it is strongly recommended that a key is left on the inside when people are present to ensure a safe exit in an emergency. The final type of deadbolt is a hybrid between a single and a double deadbolt, and is called a lockable thumbturn. It features a thumbturn on the inside that works like a normal single cylinder deadbolt, except the thumbturn can be locked using a key so it cannot lock or unlock the door. This means in a residential situation, the thumbturn can be left in an unlocked position while people are inside the house, and it will operate exactly like a standard single cylinder deadbolt. When everyone is leaving, especially for extended periods of time, the thumbturn can be easily locked so that even if someone has access to the door from the inside, the deadbolt cannot be unlocked. This type of deadbolt provides maximum flexibility and security in most situations. All deadbolts that we sell are rekeyable, however, products from some vendors are easier to rekey than others.



## Knob Locks

Knob locks are frequently installed in residential situations on exterior doors in addition to deadbolts, and are sometimes used as the primary source of security for doors. First and foremost, it should be said that knob locks should virtually never be used for security on external doors. The problem lies in the fact that the lock cylinder is in the knob itself and not the door. In almost all setups, they can be broken off the door with a hammer or bypassed using pliers or a wrench behind the knob, completely bypassing the locking cylinder. If you currently have knob locks, consider replacing them with simple passage knobs as it will provide almost as much security as long as you are using deadbolts on the same doors. When purchasing complete knob setups it is important to ensure the proper handedness and backset. For more details please see our [Backset/Handedness page](#).



## Lever Handle Locks

Lever handle locks are frequently used for inner doors in commercial settings. They are easier to open than knob locks as they have a large push down style handle rather than a knob that one must grasp and turn. Frequently when handicap accessibility is important lever locks are used. Our lever handle locks are ADA accessible and can be changed between left and right handedness. When purchasing it is important to measure the proper backset (see our [Backset/Handedness page](#)). Levers can frequently be the target of torque attacks (excessive pressure applied to the handle to try and force the lock). Some levers are "clutch" levers meaning if they are forced they just turn rather than apply pressure to the lock.



## Cam Locks

Cam locks are used in a variety of applications but are most frequently found in filing cabinets, mailboxes, and lower security OEM applications. They come in several different lengths and can use a variety of tailpieces or "cams" to interface with another locking mechanism. There is a very large variety of cam options, and we suggest you see our [Cams/Tailpieces page](#). They can rotate clockwise or counter-clockwise and the amount of rotation can be limited to 90 or 180 degrees.



## Rim/Mortise Locks

Rim cylinder and Mortise cylinder locks are frequently found on commercial doors, entry glass doors, and some apartment doors. While rim locks are very similar to mortise locks (many of our Abloy locks are rim/mortise combo locks) the actual hardware they are used on greatly differs. Rim cylinder locks are generally used in rim latch locks which are mounted on the inside of the door. Rim cylinder locks always have a long metal piece extending out the rear of the lock that runs through the door into a locking mechanism on the opposite side of the door. Rim locks are held in place by two screws from the inside that screw into the back of the rim cylinder. By contrast, mortise cylinder locks are threaded and actually screw into mortise hardware that is mounted within the door. They are held in place by a set screw and utilize a cam to actuate the locking hardware. Mortise cylinders come in several different lengths and there is a large variety of options for the cams depending on the exact mortise hardware they are being used in. We suggest reading our [Cams/Tailpieces page](#) for more information.



## Euro Profile Cylinders

Euro profile cylinders (sometimes called DIN cylinders) are frequently used in locking devices in Europe and other parts of the world. They are also used in North America in some sliding glass door locks and room dividing doors. They come in several varieties: single cylinder (one sided), double cylinder (locking cylinder on each side), and single cylinder with thumbturn (locking cylinder on one side and thumbturn on the other). The euro profile cylinder is a fairly standard form factor. The exterior (and optionally interior) lengths do vary, but the rest of the dimensions are fairly standard. Euro profile cylinders are held in place by a single screw that runs through the middle of the cylinder in most applications. Due to this single small attach point the euro profile cylinder can be easily snapped off the door if it is not of proper length or reinforced.



## Wall Mounted Locks

Wall mounted locks are locks that are actually mounted in the wall. The most common type of wall mounted lock would be the Knox-Box or fireman's box style lock found in many larger businesses as an emergency access to the buildings keys. Wall mounted locks can be used for more than just key storage. Some act as small safes or item deposits. Installation is generally done at time of construction although some wall mounted locks can be easily installed into existing buildings. Most wall locks can be mounted in a variety of wall surfaces. Frequently wall locks will be mounted with covers or alarm sensors to allow networking into the buildings security system (to detect unauthorized access).





## Interchangeable Core (IC) Cylinders

Interchangeable Core Cylinders are frequently used in larger institutions and businesses and are known for their easy ability to re-key the lock by swapping out the core without taking the lock apart. I/C Locks have two types of keys that work in the lock, the standard operator key locks and unlocks the lock like normal, while the control key, when used, pulls the entire core of the lock out without removing any screws. This is very useful when upgrading locks since the door hardware can be left alone. Just the lock cores are replaced with new ones allowing the door to be upgraded in seconds. The most popular I/C Lock brands are Best, Yale, and Schlage. Their figure-eight style cores are well known and are found in many places around the world. There are different I/C lock formats with the two most popular being Small Format Interchangeable Core (SFIC) and Large Format Interchangeable Core (LFIC). It is important to note that I/C cylinders can only be installed in housings specially meant for I/C cylinders. They cannot be installed in standard deadbolts or locks not meant to take an I/C cylinder. In almost all cases if your lock can take an IC cylinder you will see the figure eight on the outside of the lock.



## Furniture Locks

This category of locks actually covers a variety of locks including cabinet, desk, and sliding door locks. There are two primary styles of furniture lock, bolt style and push button style. Bolt style furniture locks have a piece of flat metal that extends out the side of the lock to secure the device. Frequently, bolt style locks are found on desks, cabinets, and drawers, although they are also used in a wide variety of other devices. Push button style locks have a rod that comes out the back of the lock that is used to secure things in place. When the lock is unlocked it pops out retracting the rod into the lock body. The device is then re-locked by pushing the lock back into its shell. A few of their common applications are filing cabinets and sliding doors. Frequently, furniture locks can be installed onto existing hardware that may not already have a lock installed.



## Vending/T-Handle Locks

These locks are primarily found in vending machines and T-Handle locks, although they are sometimes used in other applications. T-Handle locks are frequently exceptionally easy to replace as when you open the device you are actually pulling the t-handle lock out. Placing a new T-handle lock back in when closing the device is all that is necessary to complete the upgrade. T-Handle locks generally come in two variants, a spring latch that allows the device to be re-locked without needing a key, and a dead latch that requires a key to re-lock the device.



## Jimmy Proof Deadbolts

Jimmy proof deadbolts are a surface mount product frequently found on apartments and double doors. They are sometimes preferred due to the minimal door modifications required. They are also unique as the deadbolt interlocks with the jamb bracket preventing it from being simply pulled apart or forced easily from the outside. A surface mount lock means the lock screws into the inside of the door rather than having a complex drill pattern like a standard deadbolt. Jimmy proof deadbolts only require a hole drilled straight through the door for the rim cylinder. If you have an existing Jimmy proof deadbolt you can generally replace just the [rim cylinder](#) to upgrade your security.



## Rim Latch Locks

A rim latch lock has a standard or custom [rim cylinder](#) on one side and a surface mount latch lock on the other. Rim latch locks can auto lock the door behind you and are popular in some apartment complexes. Rim latch locks are generally not meant to take a large amount of force but can be paired with other locks when used on an external door.



## Key In Knob (KIK) Cylinders

A Key in Knob cylinder is generally found at the heart of most knobs, levers, and lower cost deadbolts. They are also popular in a variety of OEM applications and even some sliding glass doors. A KIK cylinder is generally hidden inside of the lock with only the circular face of the lock being visible. Frequently, when you take the lock apart (knob/deadbolt/etc), you will find a KIK cylinder held in place with a screw. Unfortunately, while KIK cylinders all generally look similar, there are no standard specifications to their design. This can make replacing one cylinder with another of a different brand (or a high security model) challenging. Major manufacturers generally have one or more of their own designs for a KIK cylinder. Other manufacturers sometimes duplicate the style so that their cylinders can replace those produced by other manufacturers. Aside from the different sizes that KIK cylinders can have, they also have one of several different style tails on the rear of the lock. A floating tail is where the tailpiece can rotate a certain amount without the cylinder itself rotating. A fixed tail is where the tailpiece cannot rotate without the cylinder rotating.



## Other Locks

There are still additional types of locks like European locks, switch locks, and deposit box locks to name a few. If you have questions about other types of locks, please [contact us](#).



Mortised



Tubular

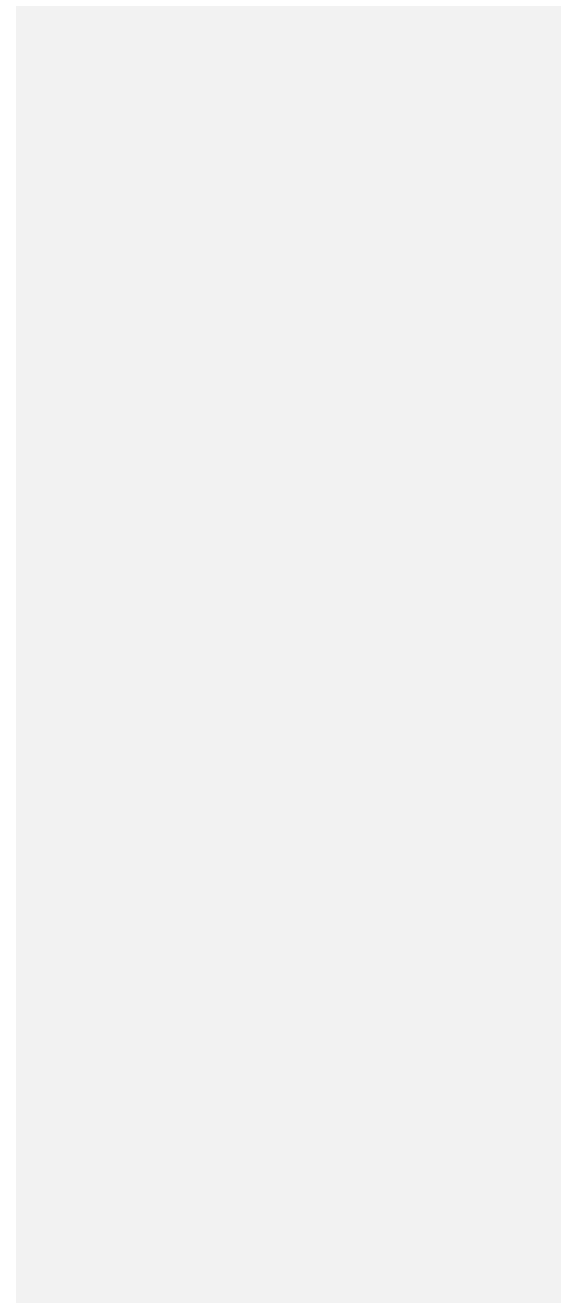

36. What type of lockset is pictured below?

- Mortised
- Unit
- Cylinder
- Lever

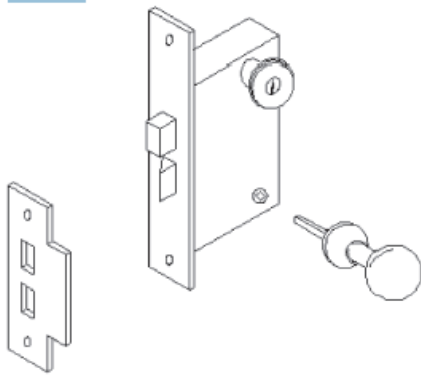

37. Efflorescence on masonry walls is caused by water-soluble salts that are present in which of the following?  
Check the two that apply.

- A. Mortar
- B. Sheathing
- C. Masonry flashing
- D. Masonry units
- E. Masonry ties
- F. Rigid insulation

1. provide easy release of the latch on the door
2. Baked enamel
3. A cricket
4. Red-cedar shingles
5. A high air leakage rate value indicates a tighter seal.
6. Movie theater
7. 12 in
8. 29
9. At D
10. recyclability
11. Automatic vent damper devices
12. full mortise
13. Carbon dioxide and dry chemical
14. Foundation design
15. Poured-in-place concrete beam-and-slab system
16. Source reduction
- 17.

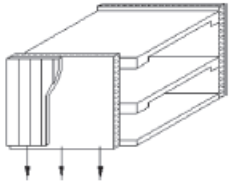

18. Number of building occupants
19. Providing a primary living space with a view of the street
20. aluminum
21. A, C
22. Waffle-grid
23. Maximizing and standardizing the panel sizes
24. Hydrostatic pressure

- 25. leakage
- 26. Shaft enclosure
- 27. Condensation in a building can contribute to mold growth.
- 28. accommodate expansion and contraction

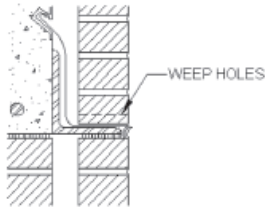

29.

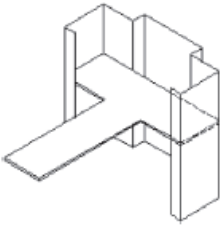

- 30.
- 31. plastering
- 32. Prestressed
- 33. helps to stabilize the foundation system
- 34. D
- 35.
- 36. Mortised
- 37. A, D



# Building Design & Construction Systems

## ACCESSIBILITY/RAMP VIGNETTE

### General Tips for Taking Accessibility/Ramp Directions

Complete the floor plan shown on the work screen by developing a ramp and stair system in accordance with the given program information. Using the tools provided, indicate all ramps, stairs, railings, wall(s), door(s), and landings required to complete the plan and indicate all landing elevations. The completed plan should reflect conformity to program and code requirements and to principles of design logic. Before beginning your solution, you should review the program and code information that can be accessed through the Vignette Index screen and familiarize yourself with the floor plan on the work screen.

### Program

1. Two small office buildings on a sloped site are to be connected by a new lobby placed at the floor elevation of the lower building.
2. Provide an accessible circulation system with a ramp and a separate stair to connect the lobby and upper level corridor.
3. Place wall(s) and door(s) only on the existing upper level to separate the lobby and the upper level exit corridor. In addition, the ramp and stair must conform to the following restrictions:
  - No portion of the ramp or stair may encroach on the existing upper level.
  - Indicate the elevation of all new landings.

### Code

Comply with the following code requirements. These are the ONLY code-related criteria you are required to use.

### Definition

**1. Accessible Means of Egress:** A continuous and unobstructed path of travel from an accessible space to a public way that is usable by a mobility impaired person. An accessible means of egress comprises the vertical and horizontal means of travel and shall include accessible exit routes, ramps, stairways, and doors.

### Maneuvering Clearances

1. The minimum width of an exit route shall not be less than 44 inches.
  - Projections into a required exit route width are prohibited, except for handrail projections.
2. The space required for a wheelchair to make a **180-degree turn** is a clear space of 60 inches in diameter, as shown in Figure 1.

**FIGURE 1: TURNING SPACE**

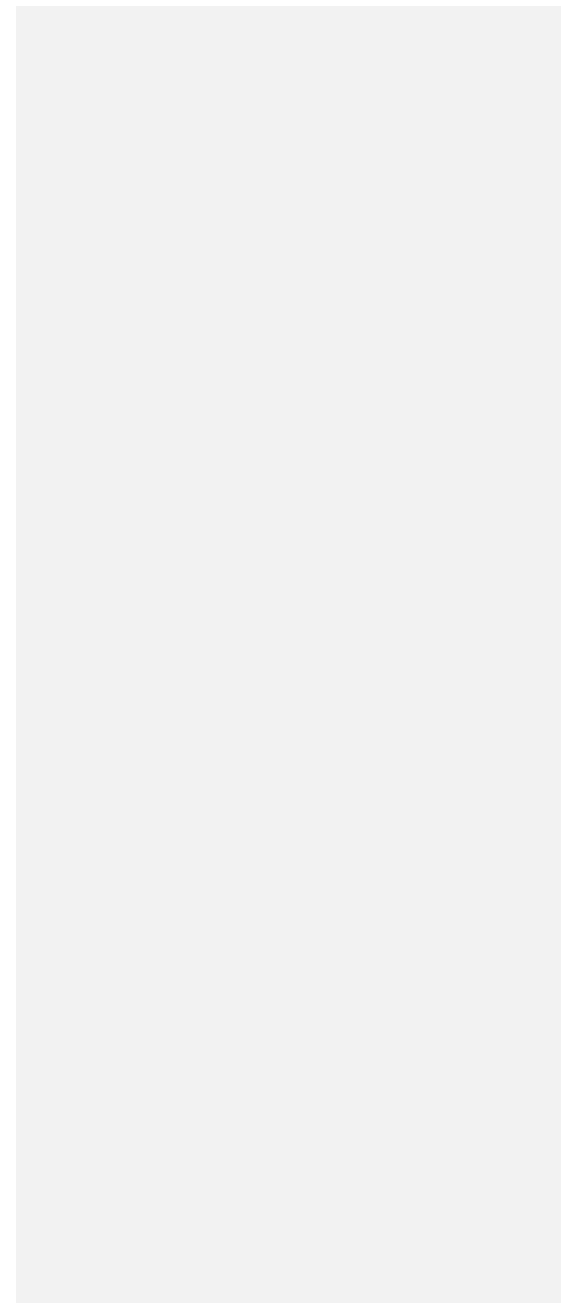
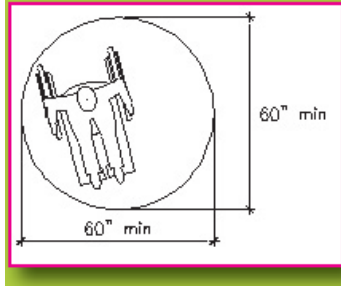

3. Minimum maneuvering clearances at doors shall be as shown in Figure 2.

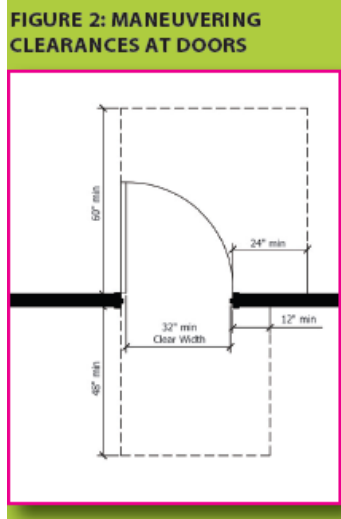

- The floor or ground area within the required clearances shall be level.

#### Ramps

1. Floors or walks in an accessible means of egress path of travel having a slope steeper than 1:20 (one unit vertical in 20 units horizontal) shall be designed as ramps.
2. **Width:** The minimum width shall not be less than 44 inches.
  - Ramps shall not reduce in width in the direction of egress travel.
  - Projections into a required ramp width are prohibited, except for handrail projections.
3. **Slope:** The maximum slope of a ramp shall be 1:12 (one unit vertical in 12 units horizontal).
4. **Landings:** Ramps shall have level landings or floor surfaces at the top and bottom of each ramp run, all points of turning, entrance, exit, and at doors.
  - The least dimension shall not be less than the required width of the ramp.
  - The least dimension in the direction of travel shall be 60 inches.
  - If ramps change direction at landings, the least dimension shall be 60 inches.

### **Stairways**

1. **Width:** The minimum width shall not be less than 44 inches.
  - Stairways shall not reduce in width in the direction of egress travel.
  - Projections into a required stairway width are prohibited, except for handrail projections.
2. **Landings:** Stairs shall have a level landing or floor at the top and bottom of each stair run.
  - The width of a landing shall not be less than the width of the stair.
  - The least dimension in the direction of travel shall be 44 inches.
  - If the path of travel changes direction between stair runs, the least dimension shall be the width of the stairs.
3. **Treads and Risers:**
  - Minimum tread depth shall be 11 inches.
  - Maximum riser height shall be 7 inches and minimum riser height shall be 4 inches.
  - There shall be no variation in any riser height or tread depth within the complete stairway system.

### **Doors**

1. **Width:** Door openings shall have a minimum clear width of not less than 32 inches, measured between the face of the door and the opposite stop with the door open 90 degrees.
2. **Exit Doors:** Exit doors shall swing in the direction of egress travel.
3. **Double-leaf Doorways:** If doorways have two independently operated door leaves, then at least one leaf shall meet the requirements for clear width and maneuvering space.

### **Guardrails**

1. Open sides of landings, floor surfaces, ramps, and stairways shall be protected by a continuous guardrail.

### **Handrails**

1. Handrails shall be provided on both sides of ramps and stairs.
  - Exception: Handrails are not required on ramps where the vertical rise between landings is 6 inches or less.
2. Handrails shall be continuous within the full length of each ramp run or stair flight.
3. Inside handrails on switchback or dogleg ramps or stairs shall be continuous between runs or flights.
4. Non-continuous handrails for ramps and stairs shall have extensions as follows:
  - Ramp handrails shall extend horizontally at least 12 inches beyond the top and bottom of the ramp run.
  - Stair handrails shall extend horizontally at least 12 inches beyond the top and bottom risers.
5. Handrails may not project more than 4 inches into the required ramp, stair, or exit route width.
6. Stairways more than 88 inches wide shall have intermediate handrails.

*Absoluteco.com*

*Greenerade.com*

*Saum Greenerade @facebook*

*Endlesschool.com*

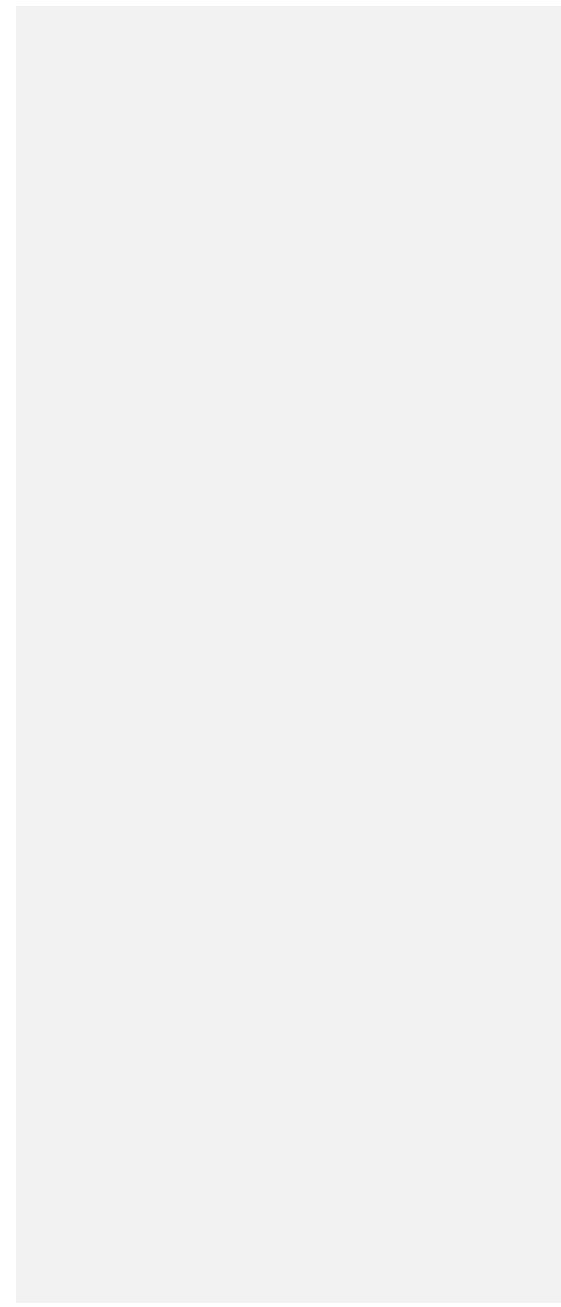

### ACCESSIBILITY/RAMP VIGNETTE – Sample Passing Solution

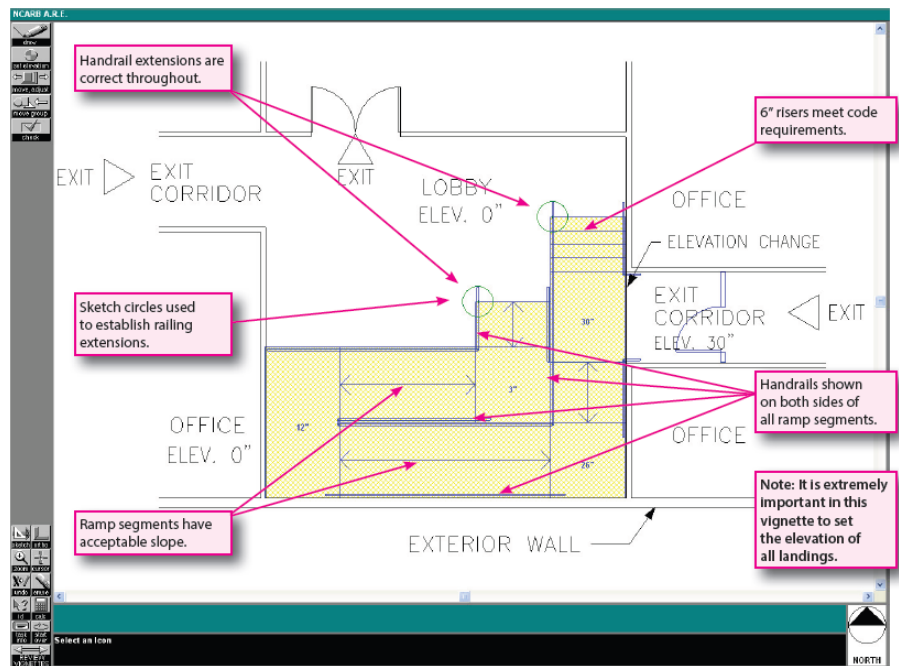

This vignette requires the candidate to connect two levels by means of an accessible egress stair and ramp system. The uppermost landing is set at the same elevation as the existing upper level. A simple ramp and stair system is shown with correct slopes for the ramps and the correct number of risers for the stairs. All necessary handrails are provided and extensions are correctly sized. The new door is the correct size and swings in the direction of egress travel.

#### Procedural Tips

- Before you draw your stairs, you should calculate how many risers you need.

- While you are drawing the stairs, the tread depth will be automatically calculated for you. This measurement is displayed in the **element information area** at the bottom of the work screen.
- Be sure to keep scrolling until you have seen all of the Code information. Click on the down arrow on the scroll bar to ensure that you have seen all of the text.
- When elements overlap, you may have trouble selecting a particular element. If this happens, keep clicking (without moving the mouse) until the desired element highlights.
- **Check** overlaps while you are working through your solution.

### Warnings

- Be sure you are aware of the elevations of various parts of the base drawing.

### Tools You Might Find Useful

- **Zoom**
- **Full-screen cursor**
- **Sketch measure** or **sketch line** tools to lay out railings

### ACCESSIBILITY/RAMP VIGNETTE – Sample Failing Solution

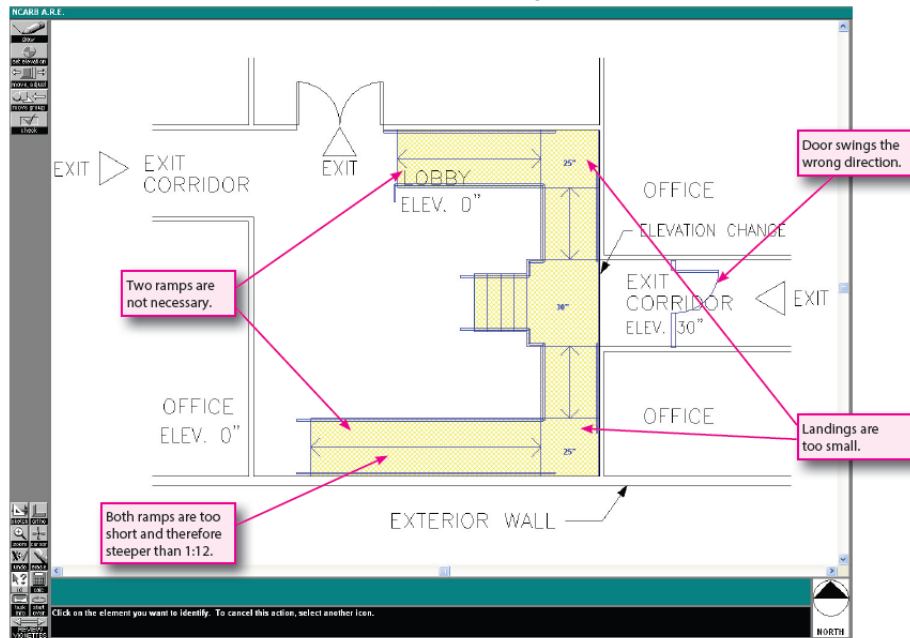

This solution creates an unusual system of two ramps with a stair between them. The ramps are both too short, making them steeper than the 1:12 maximum slope stated in the code. The top landings are too small and do not meet code requirements. Also, the new corridor door swings in the wrong direction.



## **STAIR DESIGN VIGNETTE**

### **Directions**

Using the tools provided, develop a design for an exit stairway within the existing two-story stairwell shown on the work screen. Draw the necessary components of the stairway on the two floor plans provided, and:

- Indicate the elevations of all landings.
- Indicate the elevations of all stair flights – at the top of the highest riser and at the bottom of the lowest riser – to match adjacent landing elevations.
- Include railings, i.e., guardrails and handrails.
- Connect stair flights to landings or the ground floor only.
- When using the cut stair tool, the flight of stairs should be drawn from landing to landing or from ground floor to landing.

You should develop a design that meets the given code and program requirements. Before starting to work on your stair design, you should familiarize yourself with the floor plans on the work screen as well as the program, the code, and the section that can be accessed through the Vignette Index screen.

*Absoluteco.com*

*Greenerade.com*

*Saum Greenerade @facebook*

*Endlesschool.com*

**General Tips for Taking Roof Plan**

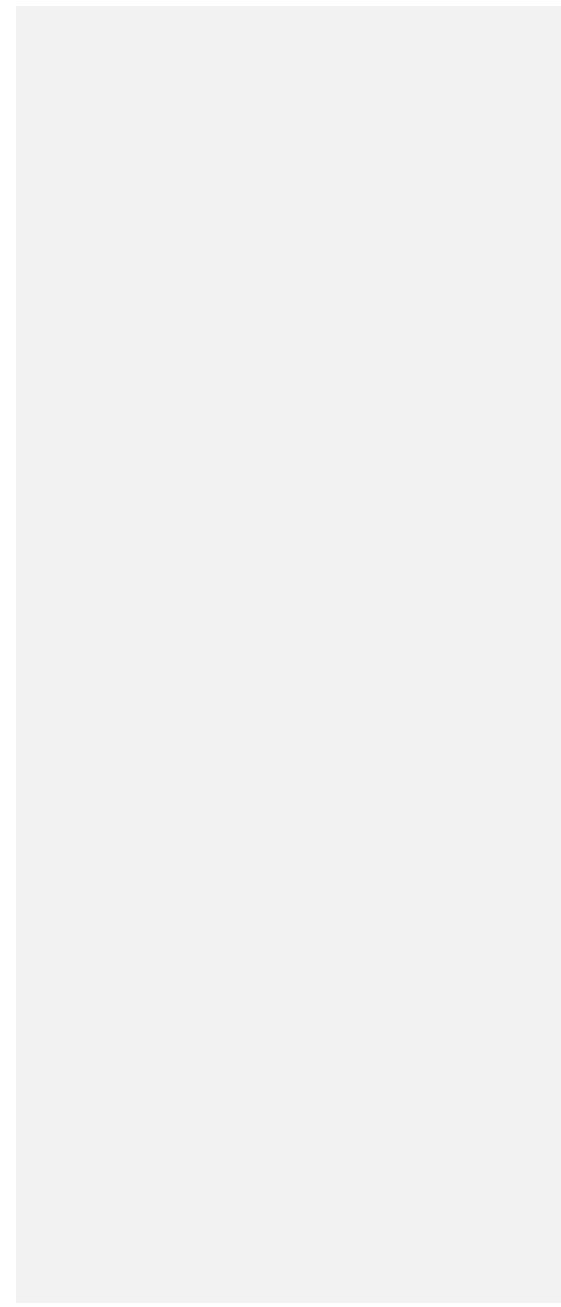

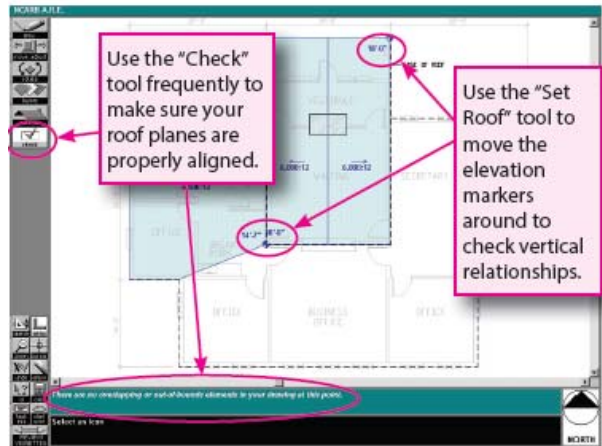
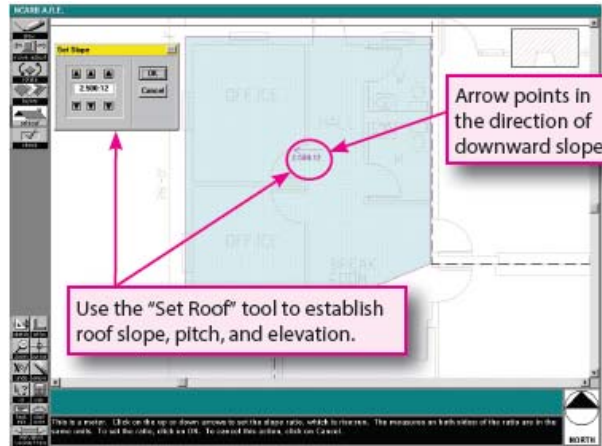

### **Directions**

The work screen shows the floor plan of a building and a simplified representation of its roof system. This representation consists of dashed lines that indicate the outermost edges of the two roofs that make up the system. When creating roof planes, confine your solution to the areas defined by the dashed lines (use no eaves or overhangs). Using the tools provided, configure these roofs for effective removal of rainwater, as follows:

- 1.** For each roof area, define the extent, slope, and spot elevations of a plane or planes designed to remove rainwater by means of roof slope, gutters, and downspouts only and to allow for any required clerestory. The outside edges of the roof planes you define must coincide with the dashed lines indicating the outermost edges of the roofs; eaves or overlapping roof planes are not to be shown.
- 2.** Indicate the location of the clerestory and all necessary gutters and downspouts by using the appropriate symbols.
- 3.** Place on the roof the HVAC condensing unit and any necessary plumbing vent stacks, skylights, and exhaust fan vents.
- 4.** Indicate any necessary flashing and crickets. The chimney shown on the plan should be considered to penetrate any roof plane that you draw over it. Before beginning your solution, you should review the program that can be accessed through the Vignette Index screen and familiarize yourself with the plan on the work screen.

### **Program**

In order to meet new accessibility standards and increased occupant loads, schematic plans are being developed for a new exit located within an existing stairwell in a two story bank building. Second floor to have area of refuge. The design for the other building exits – a second stairway and the building's main entrance – has been completed.

- 1.** Design the stairway to serve as a means of egress from all three building levels leading into the stairwell and through the exit discharge door to the sidewalk at grade (a public way).
  - The stairway must provide a continuous path from Second floor to Ground floor exit that includes a landing at the Intermediate level.
- 2.** The total occupant loads and number of exits for each level of the building are as follows:

**Building Total Occupant Number**

**Level Load of Exits**

Ground Floor 360 3

Janitor 9 1

Second Floor 180 2

3. The stairs will be constructed from pre-cast concrete components with the following dimensions:

- Landings: 12 inches deep between the landing soffit and the surface.
- Stair flights/stringers: 12 inches deep between the stair nosings and the stringer soffit measured along a line perpendicular to the soffit.

**Code**

Comply with the following code requirements. These are the ONLY code-related criteria you are required to use.

**Definitions**

**1. Means of Egress:** A continuous and unobstructed path of travel from any point in a building to a public way. A means of egress comprises the vertical and horizontal means of travel and shall include exit stairways, passageways, and exit doors.

**2. Exit Stairways:** That portion of a means of egress which is separated from all other spaces of a building by fire resistance rated construction to provide a protected way of travel to an exit door at grade. A stairway shall consist of one or more flights of stairs and the landings connecting them.

**Capacity of Exit Components**

**1. Occupant Load:** The occupant load for each exit shall be determined by dividing the total occupant load for an individual floor by the number of exits serving that floor.

- Where stairways serve more than one level, the capacity of the exit components shall be based on the individual floor with the largest occupant load, provided that the exit capacity shall not decrease in the direction of means of egress travel.

**2. Minimum Width:** The width of each exit component in inches shall not be less than the occupant load served by an exit multiplied by 0.3 nor less than the minimum width specified by this code for each component.

**Stairways**

**1. Width:** The minimum width shall be computed in accordance with Capacity of Exit Components, above, but shall not be less than 44 inches.

- Stairways shall not reduce in width in the direction of egress travel.
- Projections into a required stairway width are prohibited, except for handrail projections.

**2. Landings:** Stairs shall have a level landing or floor at the top and bottom of each stair run.

- The width of a landing shall not be less than the width of the stair.

- The least dimension in the direction of travel shall be 44 inches.
- If the path of travel changes direction between stair runs, the least dimension shall be the width of the stairs.

**3. Headroom:** The minimum headroom of all parts of a stairway shall not be less than 80 inches measured vertically from the tread nosing or from any floor surface including landings.

**4. Treads and Risers:**

- Maximum riser height shall be 7 inches and minimum riser height shall be 4 inches.
- Minimum tread depth shall be 11 inches.
- Treads shall be of uniform depth and risers of uniform height in any flight of stairs.

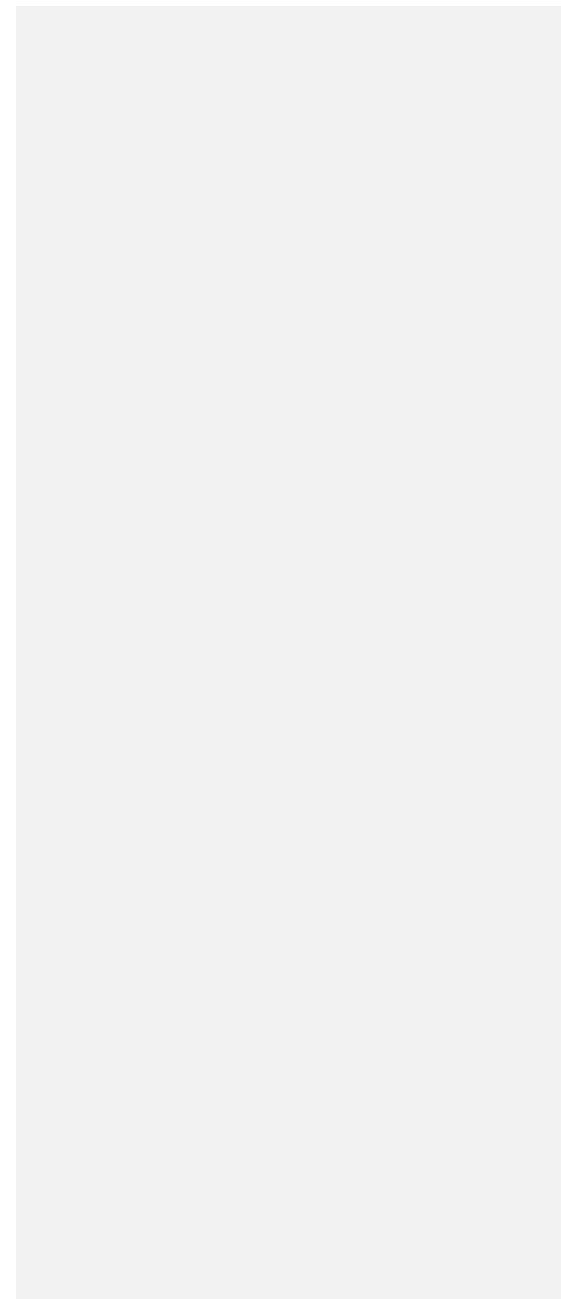

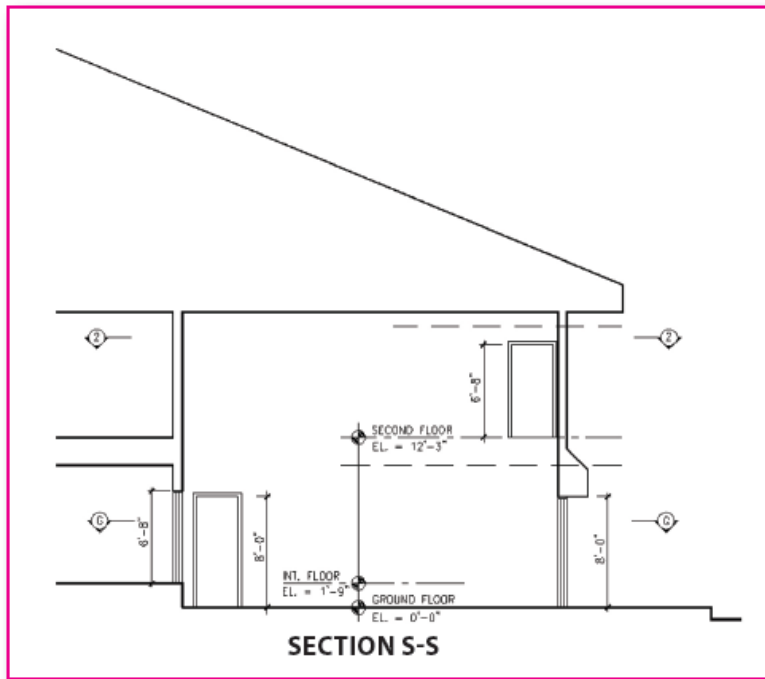

**Doors**

1. When opening, doors shall not reduce the width of landings to less than one-half of the required width.
2. There shall be a floor or landing on each side of a door and the floor surface on both sides of the door shall be at the same elevation.
3. Minimum maneuvering clearances at doors shall be as shown in Figure 1.

**Guardrails**

1. Open sides of landings shall be protected by a continuous guardrail.

**Handrails**

1. Stairways shall have continuous handrails on both sides.

- At locations where handrails are not continuous between stairway flights, including the top and bottom of a stairway, at least one handrail shall extend horizontally at least 12 inches beyond the top riser and the bottom riser.

2. Handrails shall not project more than 4 inches into the required passageway and stairway width.

**Area of Refuge**

1. An accessible area of refuge serving the second floor shall be provided within the stair enclosure.
2. The area of refuge shall be sized to accommodate one wheelchair space of 30 inches by 48 inches.
  - Such wheelchair spaces shall not reduce the required stair or landing width.
3. When areas of refuge are required, stairway width shall have a minimum clear width of 48 inches between handrails.

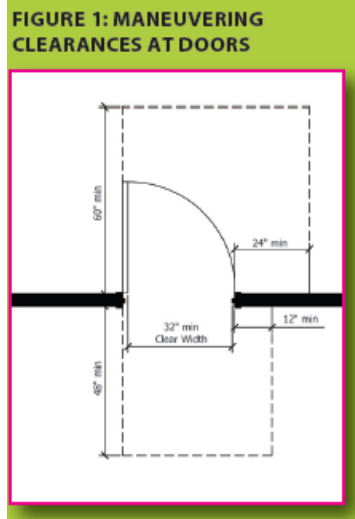



### STAIR DESIGN VIGNETTE - Sample Passing Solution

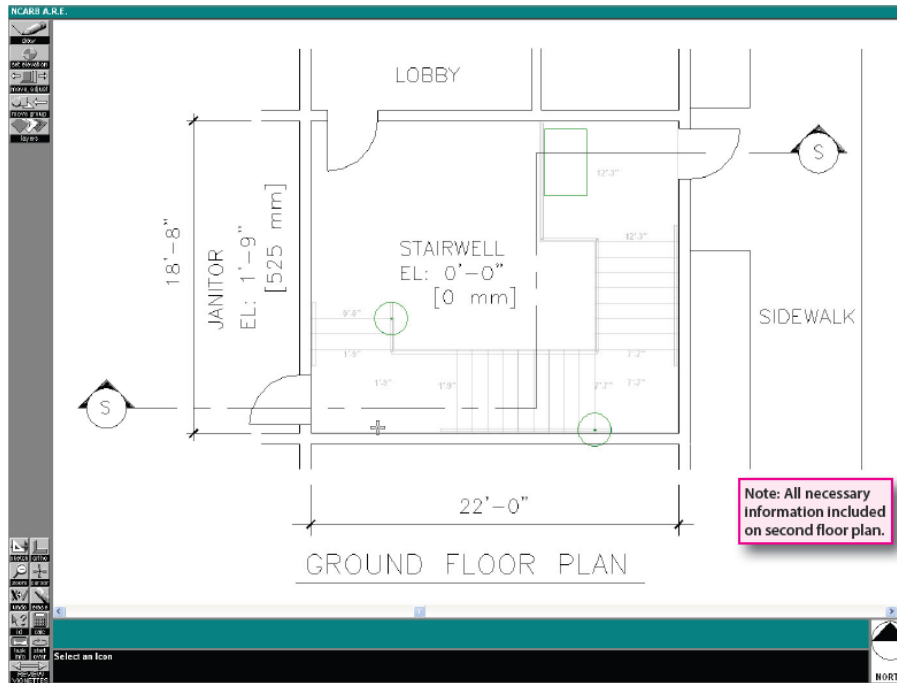

#### First Floor

Because the design of the stairs for this particular solution does not obscure other portions of the stair, all necessary information can be created and displayed on the Second Floor Plan. It is not necessary to utilize the "Cut Stair" tool.

#### Procedural Tips

- Pay attention to the order of tasks specified in the Vignette Directions.

- Calculate the number of risers you need before you begin to lay out your stairs.
- The tread depth is calculated for you. It appears in the **element information area** at the bottom of the work screen.
- The question marks at each end of the stair represent the elevations at the points of attachment of a stair to its landings.
- Change **layers** at the appropriate level as indicated by the ground floor cut line in the section drawing.
- When elements overlap, you may have trouble selecting a particular element. If this happens, keep clicking (without moving the mouse) until the desired element highlights.

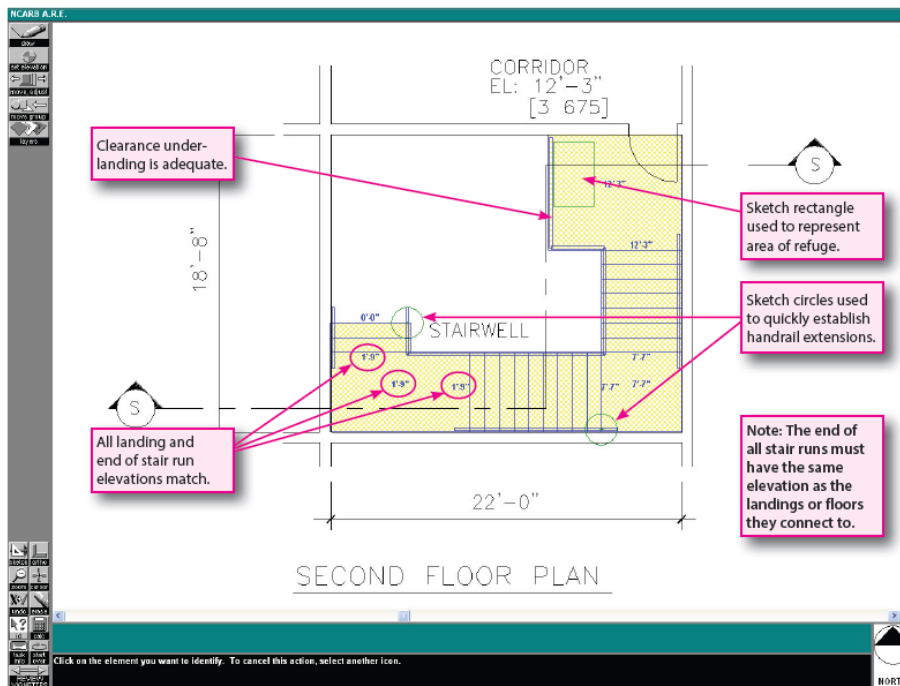

*Absoluteco.com*

*Greenerade.com*

*Saum Greenerade @facebook*

*Endlesschool.com*

### **Second Floor**

This vignette requires the insertion of a new stair system connecting three levels in an existing space. In this solution, the stairs are wide enough at all runs, do not get narrower in the direction of egress, and do not block egress at the ground floor level. The intermediate landing is set at the same elevation as the janitor room it serves as shown on the given section. The upper landing is located at the correct elevation and extends to allow for an area of refuge. The solution provides adequate headroom where required considering the thickness of the structure as given in the program.

### **Warnings**

- If you do not draw a stair or a landing in a given location within a stairwell, the scoring mechanism will assume that the area is open to below.
- You must indicate the elevation of the stair and the landings separately even if the elevations are the same.
- Be sure you are aware of the elevations of various parts of the base drawing.

### **Tools You Might Find Useful**

- **Zoom**

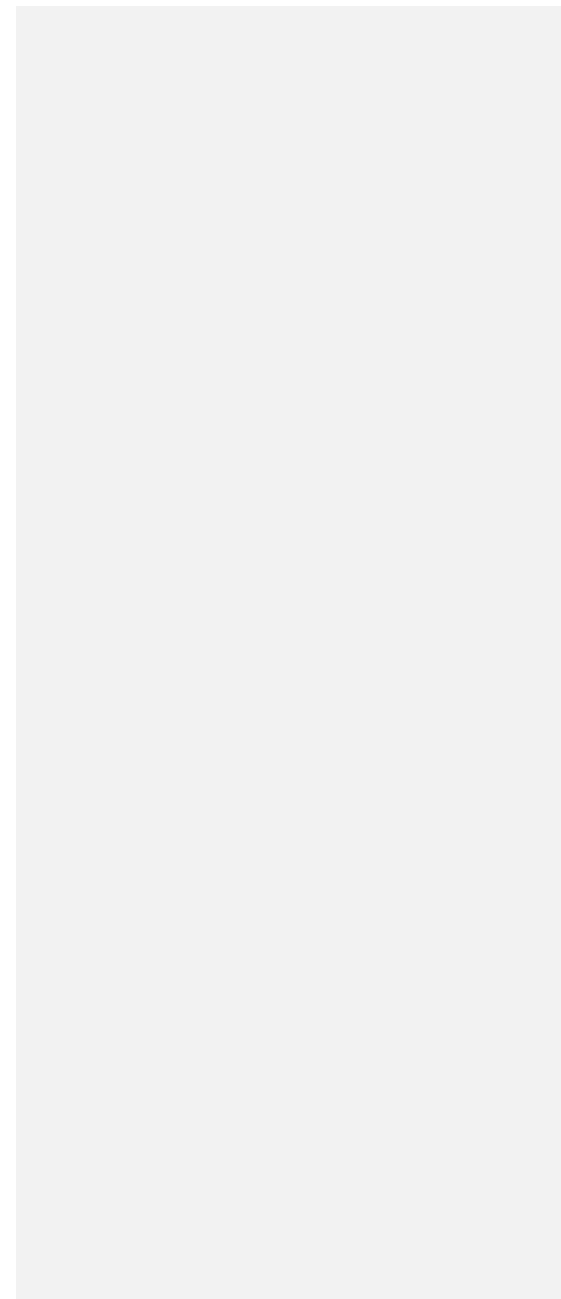

### STAIR DESIGN VIGNETTE - Sample Failing Solution

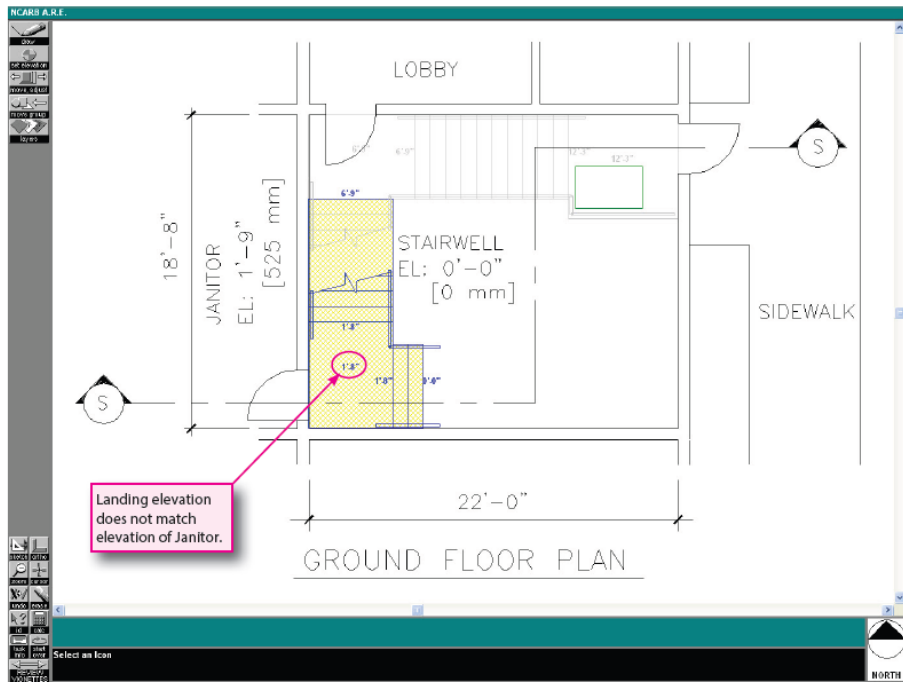

#### First Floor

This solution also takes a simple approach to the same problem, but fails in three major areas. The landing located near the janitor room is not at the correct elevation.

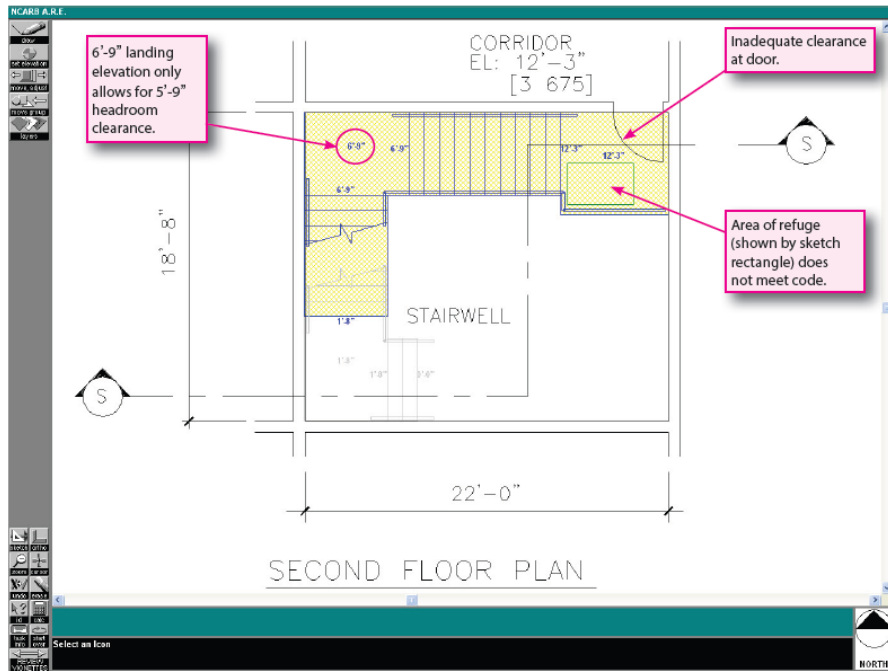

**Second Floor**

Additionally, the area of refuge indicated by the sketch rectangle on the upper landing is inadequate. A rectangle representing the area of refuge is not required to be shown, but the necessary space for the area of refuge must be provided according to the code. Also, the upper intermediate landing only allows for 69 inches of headroom below. This does not meet the minimum code requirement for 80 inches of clear headroom.

*Absoluteco.com*

*Greenerade.com*

*Saum Greenerade @facebook*

*Endlesschool.com*

## **ROOF PLAN VIGNETTE**

### **General Tips for Taking Roof Plan**

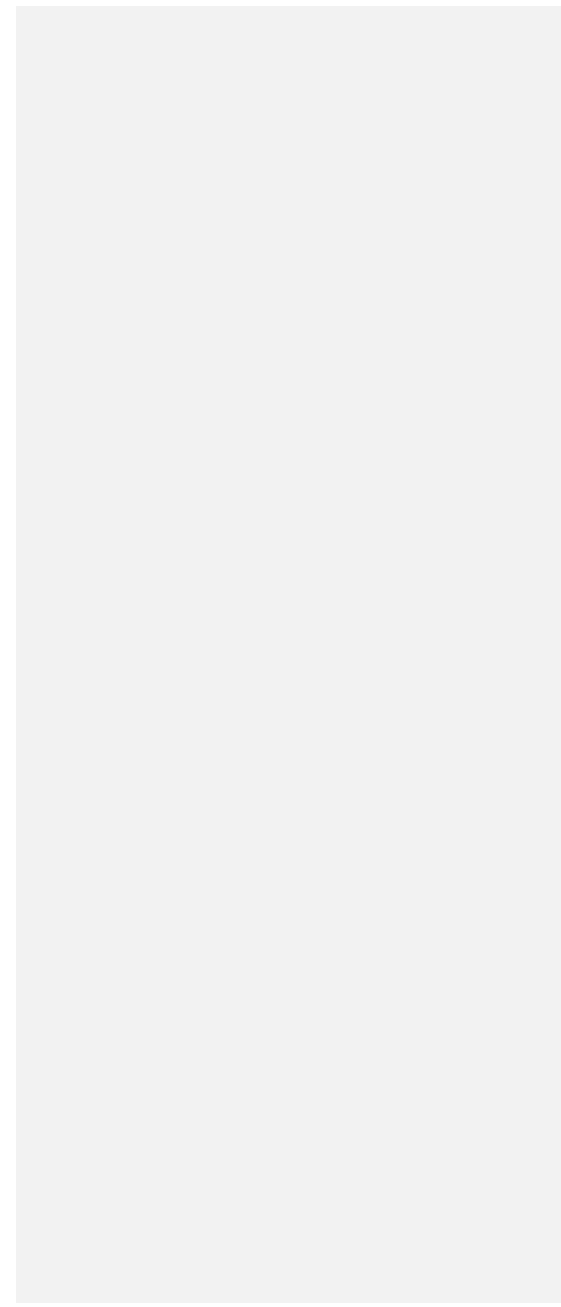

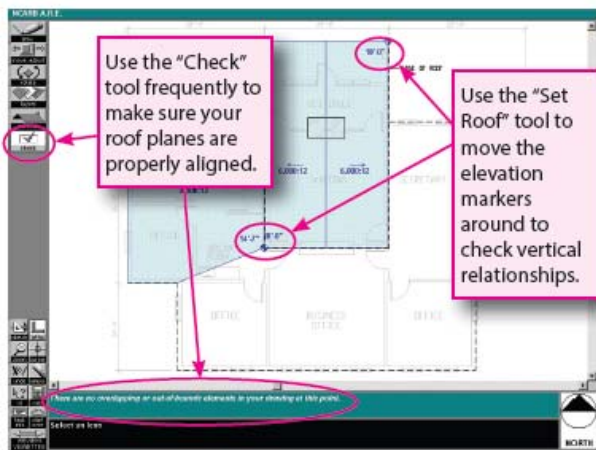
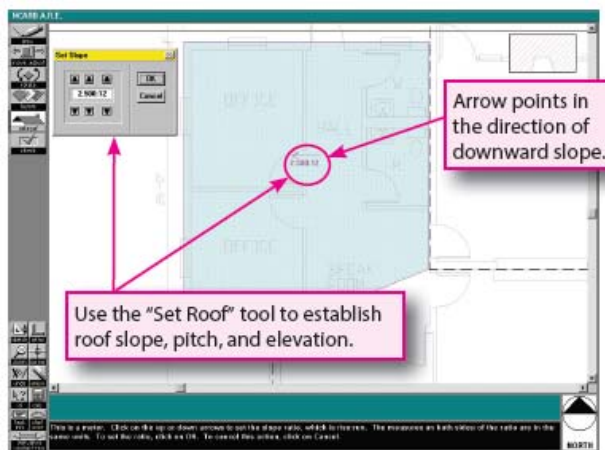

### **Directions**

The work screen shows the floor plan of a building and a simplified representation of its roof system. This representation consists of dashed lines that indicate the outermost edges of the two roofs that make up the system. When creating roof planes, confine your solution to the areas defined by the dashed lines (use no eaves or overhangs). Using the tools provided, configure these roofs for effective removal of rainwater, as follows:

1. For each roof area, define the extent, slope, and spot elevations of a plane or planes designed to remove rainwater by means of roof slope, gutters, and downspouts only and to allow for any required clerestory. The outside edges of the roof planes you define must coincide with the dashed lines indicating the outermost edges of the roofs; eaves or Over lapping roof planes are not to be shown.
2. Indicate the location of the clerestory and all necessary gutters and downspouts by using the appropriate symbols.
3. Place on the roof the HVAC condensing unit and any necessary plumbing vent stacks, skylights, and exhaust fan vents.
4. Indicate any necessary flashing and crickets. The chimney shown on the plan should be considered to penetrate any roof plane that you draw over it. Before beginning your solution, you should review the program that can be accessed through the Vignette Index screen and familiarize yourself with the plan on the work screen.

### **Program**

Your office is designing a regional craft center. The following requirements must be considered in preparation of the roof plan.

#### **General**

1. The building consists of two volumes, one high and one low. Each volume has a roof height and slope requirement.

#### **Roof Drainage**

1. The building is located in a temperate climate with moderate annual rainfall.
2. Only roof slope, gutters, and downspouts are to be used for removal of rainwater.
3. Downspouts should not conflict with any door, window, or clerestory window.
4. Rainwater should not discharge from the edge of an upper roof directly onto a lower roof or from any roof or gutter directly onto the ground.

#### **Construction**

1. Finished floor elevation is 0'-0". Minimum ceiling height is 8'-0".
2. All roof areas must have a positive slope.
3. The roof over the exhibition room shall have a slope between 6:12 and 12:12.
  - The roof and structural assembly is a total of 18 inches thick.
4. The roof over the remaining spaces shall have a slope between 2:12 and 5:12.
  - The roof and structural assembly is a total of 18 inches thick.
5. The exhibition room is to have a horizontal clerestory window 24 inches in height located in the existing west wall.
  - The clerestory sill is included in the overall height dimension.
6. Natural light must be provided for all rooms by means of windows, clerestory window, or skylight.
  - Skylights must be provided only where no windows are shown and no clerestory window has been specified.
  - Skylights are not required in halls, storage rooms, or closets.



7. Flashing must be provided at all roof/wall surface intersections, including chimneys.

- HVAC condensing units, plumbing vent stacks, exhaust fan vents, skylights, and gutters are self-flashing and require no additional flashing or crickets.

***Mechanical***

1. The HVAC condensing unit must be placed on a roof with a slope of 5:12 or less.

- Maintain a minimum of 3 feet clearance from all roof edges.
- Do not place in front of the clerestory window.

2. Provide one (1) exhaust fan vent for each toilet room.

3. Provide plumbing vent stacks through roof where required to vent plumbing fixtures

## STAIR DESIGN VIGNETTE - Sample Failing Solution

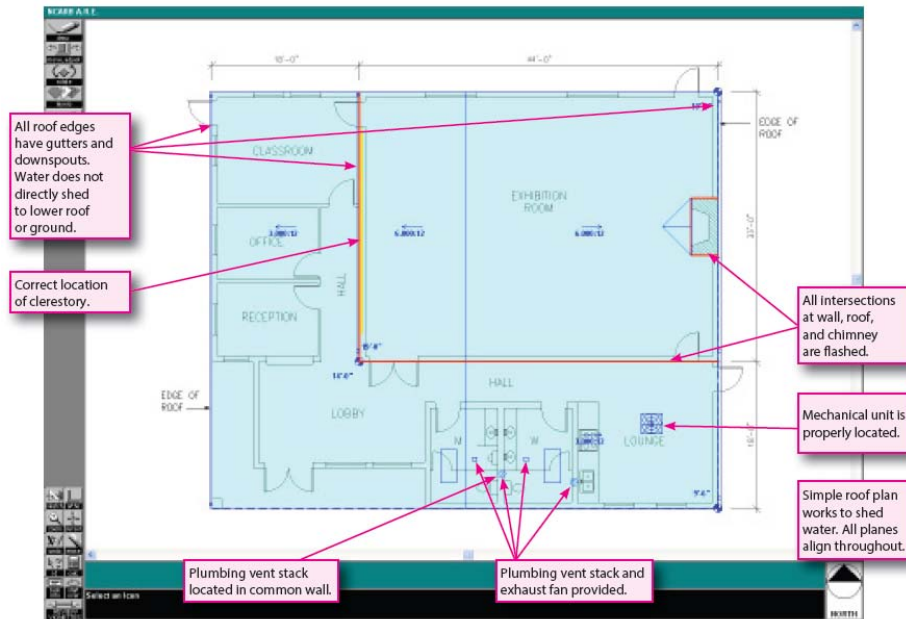

In this solution, the slope of the upper roof is 6:12 and falls within the required slope. The roof elevations are correctly set at each corner of the roof. At the low corner of the upper roof, there is adequate difference between the two roof levels. This allows placement of the required 24-inch horizontal clerestory window on the west wall of the Exhibition Room and the necessary 18-inch roof structure above. The lower roof slopes are set at 3:12 with a low point at 9 feet 6 inches. Flashing is provided at all roof/wall surface intersections, and there are gutters and downspouts at the eaves. Skylights are provided in spaces with no exterior windows and all plumbing fixtures are close to a plumbing vent stack.

### Procedural Tips

- To see the limits of the roof, turn off **Display floorplan** under the **layers** menu.
- Use the **check** tool to ensure that your roof planes are drawn within the given limits of the roof.
- Where roof planes meet, the lines indicating the edges must coincide. The **zoom** tool may be helpful in accomplishing this.

*Absoluteco.com*

*Greenerade.com*

*Saum Greenerade @facebook*

*Endlesschool.com*

- While working with the **set roof** tool, refer to the **instructions area** at the bottom of the work screen. The instructions will guide you in using this tool.
- Change the **cursor** to a full-screen crosshair to assist in aligning your roof plane with the given roof edge. **Ortho** is also helpful for aligning.
- When elements overlap, you may have trouble selecting a particular element. If this happens, keep clicking (without moving the mouse) until the desired element highlights.

### **Note**

Be careful to follow the perimeter edges for both the upper and lower roof planes. Use the "Check" tool frequently.

### ROOF PLAN VIGNETTE - Sample Failing Solution

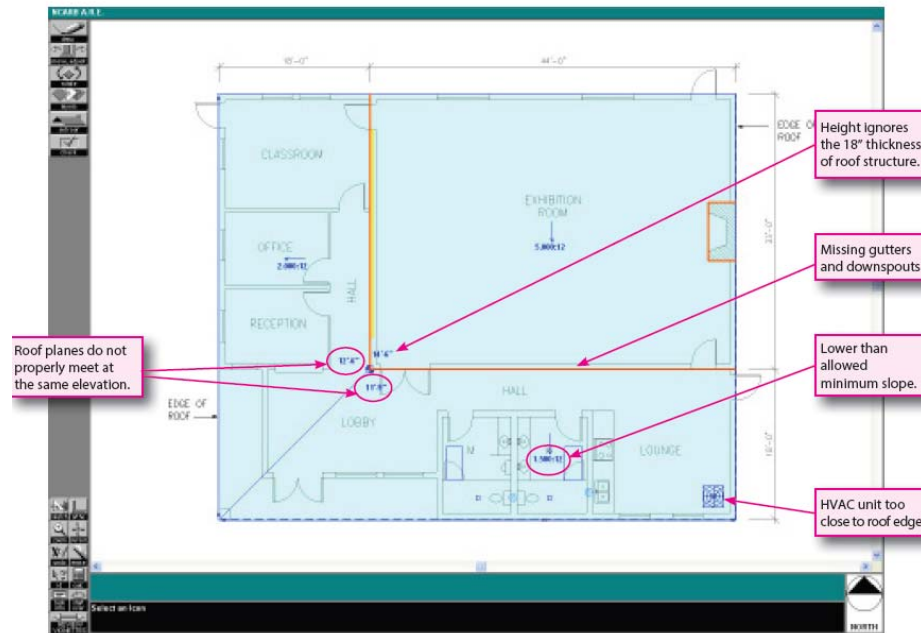

This solution generally sheds water but has some major technical flaws. The main problems are with the roof slopes and corner elevations on the three roof planes that make up the roof system. The slope of the lower level, south-facing plane is set shallower than the program allows, and the top corners of the two lower level planes do not align at the same elevation. The HVAC unit is too close to the roof edge. The upper roof is missing gutters and allows the water to shed off the roof directly onto the lower roof and ground.

#### Warnings

- The dashed lines labeled Edge of Roof (on the work screen) are the outer limits of the roof. Do not extend your roof planes beyond these lines.
- Gutters and downspouts may be placed beyond the outer limits of the roof.

[Absoluteco.com](http://Absoluteco.com)

[Greenerade.com](http://Greenerade.com)

[Saum Greenerade @facebook](#)

[Endlesschool.com](http://Endlesschool.com)

### Tools You Might Find Useful

- **Set roof** tool to make calculating roof elevation easier

## REFERENCES

The following references are presented to assist candidates in preparation for the examination. This list represents texts that have content covered in this division of the examination. This is not intended to be an exhaustive list of all possible reference materials for the subject area. NCARB makes no guarantee that the various references are currently in print.

### The Architect's Handbook of Professional Practice

Joseph A. Demkin, AIA, Executive Editor  
The American Institute of Architects  
John Wiley & Sons, latest edition

### The Architect's Portable Handbook, Second Edition

Pat Guthrie  
McGraw-Hill, 2003

### The Architect's Studio Companion: Technical Guidelines for Preliminary Design

Edward Allen and Joseph Iano  
John Wiley & Sons, latest edition

### Architectural Graphic Standards

Charles G. Ramsey and Harold R. Sleeper  
The American Institute of Architects  
John Wiley & Sons, latest edition

### Building Codes Illustrated: A Guide to Understanding the International Building Code

Third Edition  
Francis D. K. Ching and Steven R. Winkel, FAIA  
John Wiley & Sons, 2009

### Building Construction Illustrated

Francis D. K. Ching and Cassandra Adams  
John Wiley & Sons, latest edition

### Building Design and Construction Handbook, Sixth Edition

Frederick S. Merritt and Jonathan T. Ricketts  
McGraw-Hill, 2000

### Dictionary of Architecture and Construction

Cyril M. Harris, Editor

[Absolute.com](http://Absolute.com)

[Greenerade.com](http://Greenerade.com)

[@facebook](https://www.facebook.com/SaumGreenerade)

[Endlesschool.com](http://Endlesschool.com)

McGraw-Hill, 2005

**Fundamentals of Building Construction, Materials, and Methods**, Fourth Edition

Edward Allen  
John Wiley & Sons, latest edition

**Historic Preservation: An Introduction to Its History, Principles, and Practice**

Norman Tyler  
W. W. Norton & Company, latest edition

**The HOK Guidebook to Sustainable Design**

Sandra F. Mendler, AIA, and William Odell, AIA  
John Wiley & Sons, 2006

**Illustrated Dictionary of Architecture**,

Second Edition  
Ernest Burden  
McGraw-Hill, 2002

**Interior Graphic Standards**

Maryrose McGowan and Kelsey Kruse  
John Wiley & Sons, 2003

**Landscape Planning: Environmental Applications**,

Fourth Edition  
William M. Marsh  
John Wiley & Sons, 2005

**Means Building Construction Cost Data**

RS Means Company, latest edition

3839 Birch Newport Beach, Ca 92660. 949 852 8700.

**For Internal Use Only- Do not Copy**

183

**USC ARE BDCS 4 Series**  
12/21/2013